

# TEAC®

## SERVICE MANUAL

# MV-308/307

### Video Cassette Recorder



MASTER COPY  
DO NOT REMOVE

#### CAUTION

⚠ Parts marked with this sign are safety critical components. They must always be replaced with identical components—refer to the appropriate parts list and ensure exact replacement.

# TABLE OF CONTENTS

SPECIFICATIONS .....	4
STANDARD MAINTENANCE .....	5
1. SERVICE SCHEDULE OF COMPONENT .....	5
2. CLEANING .....	5
SERVICE JIG AND TOOLS .....	6~7
1. SERVICE JIG AND TOOLS .....	6
2. HOW TO ASSEMBLE THE JIGS .....	7
DISASSEMBLY .....	8~20
ELECTRICAL MAIN PARTS LIST .....	21~24
PRACTICAL SERVICE FIGURE .....	25
BLOCK DIAGRAM .....	27~36
● BLOCK DIAGRAM-1 (VIDEO) .....	27~28
● BLOCK DIAGRAM-2 (SERVO/SYSCON, HV-G50/G53/G55) .....	29~30
● BLOCK DIAGRAM-3 (SERVO/SYSCON, HV-G51) .....	31~32
● BLOCK DIAGRAM-4 (SYSTEM CONTROL) .....	33
● BLOCK DIAGRAM-5 (TUNER) .....	34
● BLOCK DIAGRAM-6 (AUDIO/POWER UNIT) .....	35~36
WIRE HARNESS DIAGRAM .....	37~38
WIRING-1 (VIDEO/TUNER/SERVO/SYSCON) .....	39~40
SCHEMATIC DIAGRAM-1 (VIDEO) .....	41~42
SCHEMATIC DIAGRAM-2 (SERVO/SYSCON) .....	43~45
DRUM SERVO SYSTEM TIMING CHART .....	46~47
NOISE CANCELLER TIMING CHART .....	48
IC BLOCK DIAGRAM .....	49
SYSTEM SWITCH MODE .....	50
SCHEMATIC DIAGRAM-3 (TUNER) .....	51~52
WIRING-2 (POWER UNIT/PRE AMP./AUDIO/MECHANISM) .....	53~54
SCHEMATIC DIAGRAM-4 (PRE AMP./AUDIO/POWER UNIT) .....	55~58
WIRING-3 (TIMER/DISPLAY) .....	59~60
SCHEMATIC DIAGRAM-5 (TIMER/DISPLAY) .....	61~62
WAVE FORM (VIDEO WAVE FORM) .....	63~67
(SERVO WAVE FORM) .....	68~69
(TUNER WAVE FORM) .....	69~71
(AUDIO WAVE FORM) .....	71~73
(POWER WAVE FORM) .....	74~76
(TIMER WAVE FORM) .....	76~77
IC DESCRIPTION .....	78~85
CIRCUIT DESCRIPTION .....	86~87
1. AUTO TRACKING .....	86
2. AUTO NOISE CANCELLER .....	87
ELECTRICAL ADJUSTMENT .....	88~90
1. POWER VOLTAGE ADJUSTMENT .....	88
2. CLOCK FREQUENCY ADJUSTMENT .....	88
3. SERVO CIRCUIT ADJUSTMENT .....	89
4. VIDEO CIRCUIT ADJUSTMENT .....	90
MECHANICAL ADJUSTMENT .....	91~102
1. TAPE TRANSPORT ADJUSTMENT FLOWCHART .....	91
2. TAPE RUNNING POSITION ADJUSTMENT .....	92~94
3. ACE HEAD ADJUSTMENT .....	95
4. X VALUE ADJUSTMENT .....	96~99
5. ENVELOPE WAVE FORM ADJUSTMENT .....	99~100
6. ACE HEAD HEIGHT/ACE HEAD TILT ADJUSTMENT .....	101
7. ACE HEAD AZIMUTH ADJUSTMENT .....	102
EXPLODED VIEW, MECHANICAL PARTS LIST .....	103~117
● EXPLODED VIEW-1 .....	103~104
● EXPLODED VIEW-2 .....	105~106
● EXPLODED VIEW-3 .....	106~107
● EXPLODED VIEW-4 .....	108~109
● EXPLODED VIEW-5 .....	110~111
● EXPLODED VIEW-6 .....	112~113
● EXPLODED VIEW-7 .....	114~115
● EXPLODED VIEW-8 .....	116~117
● ACCESSORIES PARTS LIST .....	118

# SPECIFICATION

<b>Recording/playback system</b>	Video: Rotary 2 heads helical scan system Audio: Fixed head
<b>Video signal</b>	PAL/B/G 625 lines, 50 Hz
<b>Recording/playback time</b>	4 hours max. with E-240 tape, standard speed
<b>Fast forward/rewind time</b>	Less than 300 sec., with E-240 tape
<b>Tape speed</b>	Standard speed, 23.39 mm/sec.
<b>Tape width</b>	12.65 mm
<b>Usable cassette</b>	VHS video cassette
<b>Timer display</b>	24-hour cycle, day, hour, minute, digital fluorescent display
<b>Timer recording</b>	7 programs within 2 weeks 1 program for weekly recording
<b>Channel coverage</b>	Band L (VHF low) 0 – 5 H (VHF high) 5A – 11 U (UHF) 21 – 69
<b>RF output</b>	Low (0) High (1)
<b>RF output level</b>	74 dB

<b>Video input</b>	0.5 – 2.0 Vp-p, 75 ohms unbalanced
<b>Video output</b>	1.0 Vp-p, 75 ohms unbalanced
<b>Horizontal resolution</b>	240 lines (nominal)
<b>Video S/N (luminance)</b>	43 dB (nominal)
<b>Audio input</b>	–10 dBs (nominal)
<b>Audio output</b>	–8 dBs, 2.2 k ohms
<b>Audio frequency response</b>	200 Hz – 8 kHz
<b>Audio S/N</b>	41 dB (nominal)
<b>Operating temperature</b>	5°C – 40°C
<b>Power requirements</b>	240 V AC
<b>Power consumption</b>	21 watts
<b>Dimensions</b>	380 (W) × 95 (H) × 315 (D) mm
<b>Weight</b>	Approx. 5.1 kg
<b>Accessories</b>	Remote control unit (1) AC power cord (1) Antenna cable (1) Batteries (2)

Design and specifications are subject to change without notice for the purpose of performance improvement.

# STANDARD MAINTENANCE

## 1. SERVICE SCHEDULE OF COMPONENT

○ : Check    ● : Change

DECK		Periodic Service Schedule			
Ref. No.	Parts Name	1000 h	2000 h	3000 h	4000 h
2-2	UPPER DRUM	○	●	○	●
4-6	PINCH ROLLER A		●		●
3-32	CAPSTAN MOTOR ASSY		●		●
5-27	CLUTCH ASSY		●		●
4-46	LM ASSY			●	
6-22	MAIN BELT		●		●
3-5	BT BAND ASSY		●		●
5-29	DRIVE BELT		●		●
4-41	BRAKE SHOE		●		●
6-1	LOADING BELT		●		●
5-26	FL BELT		●		●
2-5	DRUM EARTH			●	
4-21	ACE HEAD HV-225211			●	
3-25	REEL ASSY			●	
4-50	FULL ERASE HEAD			●	

**NOTE :**

1. Clean all parts for the tape transport.  
Upper Drum with video head / Pinch Roller A  
ACE Head / Full Erase Head

2. After cleaning up the parts, perform all DECK ADJUSTMENT.

## 2. CLEANING

### 1. CLEANING OF "VIDEO HEAD" (See Figure-1)

Head cleaning by using a chamois skin.

— Procedure —

- 1) Remove the "Cabinet, Steel".
- 2) Put on a glove (thin type) to avoid touching the "Upper drum" and "Lower drum" with bare hand.
- 3) Put a few drops of alcohol on the Chamois skin, and by slightly placing it against the "Head tip", allow the "Upper drum" to turn the right and left.

— Remark —

- 1) The video head is of very hard material, but since it is very thin, avoid cleaning it vertically.
- 2) Wait for the cleaned part to dry out, before operating the unit.
- 3) Do not reuse the Stained chamois skin.

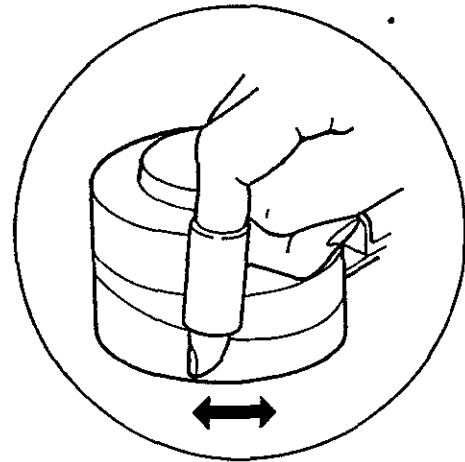

Fig-1

### 2. CLEANING OF "ACE HEAD" (See Figure-2)

Head cleaning by using a chamois skin.

— Procedure —

- 1) Remove the "Cabinet, Steel".
- 2) Put a few drops of alcohol on the chamois skin, clean up the "Audio control head", being careful not to damage the "Upper drum" and other tape running parts.

— Remark —

- 1) Avoid cleaning "ACE Head" vertically.
- 2) Wait for the cleaned part to dry well, before operating the unit.

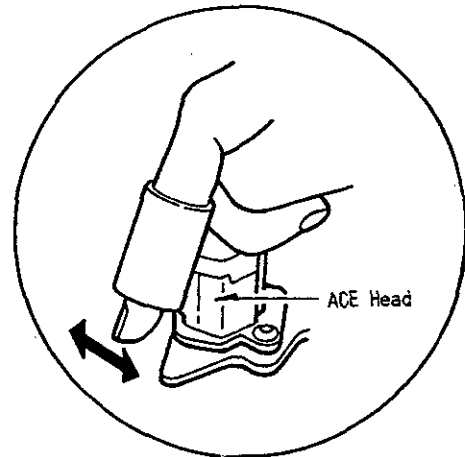

Fig-2

# SERVICE JIG AND TOOLS

## 1. SERVICE JIG AND TOOLS

Ref. No.	Name	Adjustment
J-1	Torque Meter (FSJ-VHT-063)	Back Tension
J-2	Special Driver (SMALL)	Tape Running Position, Envelope Wave Form
J-3	Special Driver (LARGE)	X Value
J-4	Mirror	Tape Transportation Check
J-5	Alignment Tape (TTV-P2)	X Value, Envelope Wave Form, ACE Head Azimuth
J-6	Alignment Tape (TTV-P1)	ACE Head Height / ACE Head Tilt
J-7	Box Driver M3	Tape Running Position, X Value, Envelope Wave Form
J-8	EXT. PCB. KIT (A) (Parts No. 09-054-012-010)	HA (For repair of circuit board)

J-1, J-5, J-6

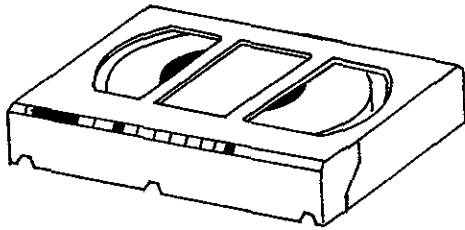

J-2, J-3

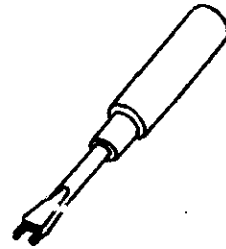

J-4

J-7

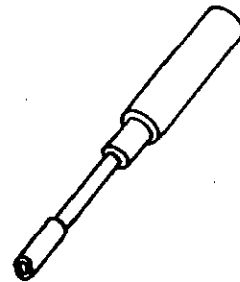
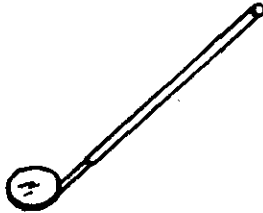

## 2. HOW TO ASSEMBLE THE JIGS

### 1. Assembling the J-8 (See Figure-1)

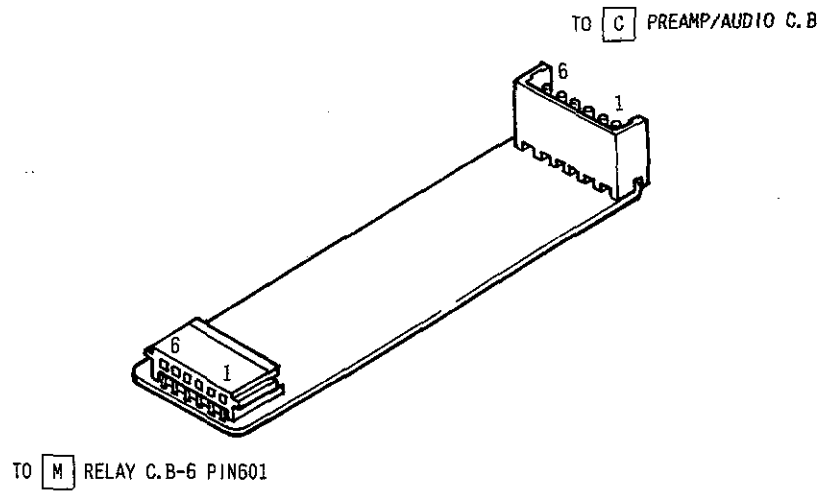

Fig-1

Place the circuit board with the solder side down as shown in the figure above and assemble the connectors, taking care of their directions.

### 2. Using the J-8 (See Figure-1)

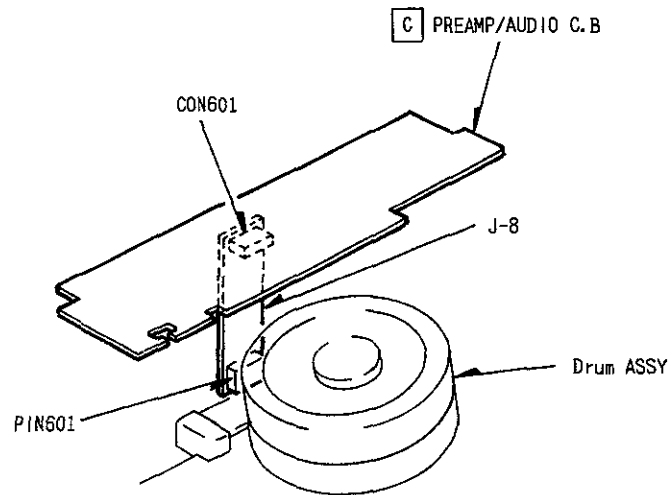

Fig-1

Use this jig when servicing the "Preamp/Audio circuit board".

# DISASSEMBLY

## 1. "CABINET FRONT ASSY" REMOVAL (See Figure-1)

- 1) Remove 4 screws (A) holding the "Cabinet, Steel".
- 2) Remove 7 screws (B) holding the "Bottom, Plate".
- 3) Remove 3 screws (C) and release 5 hooks to remove the "Cabinet front ASSY".

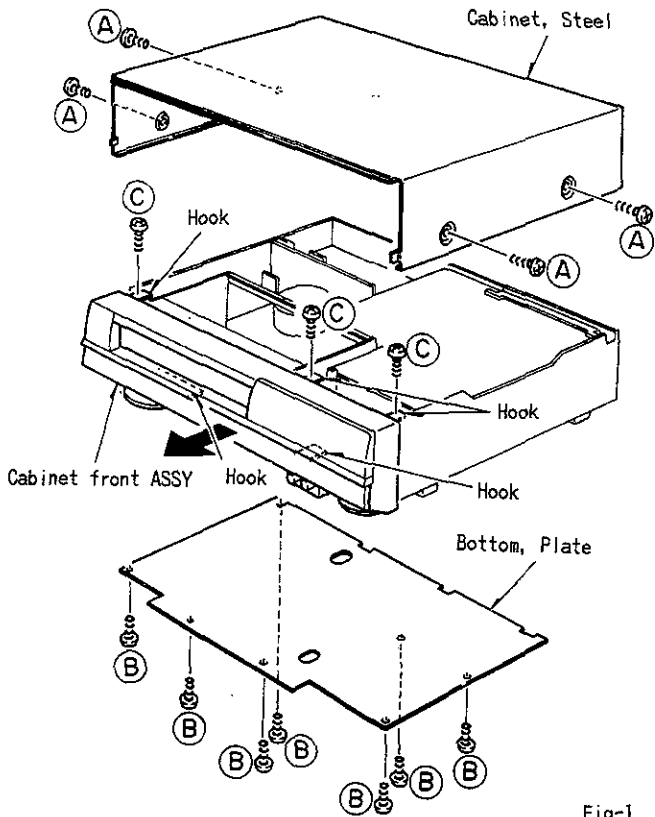

Fig-1

## 3. "MECHANISM ASSY" REMOVAL (See Figure-3)

- 1) Remove screw (A) and disconnect the connector to remove the "Preamp/audio circuit board" in the direction of the arrow.
- 2) Remove 3 screws (B) holding the "Mechanism ASSY".

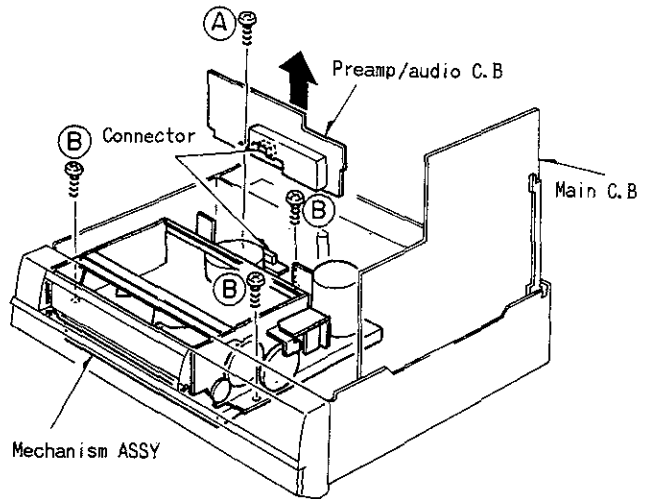

Fig-3

## 2. "POWER UNIT ASSY" AND "MAIN CIRCUIT BOARD" REMOVAL

(See Figure-2)

- 1) Remove 5 screws (A) holding the "Main circuit board".
- 2) Remove 2 screws (B) and 2 screws (C) holding the "Power unit ASSY".

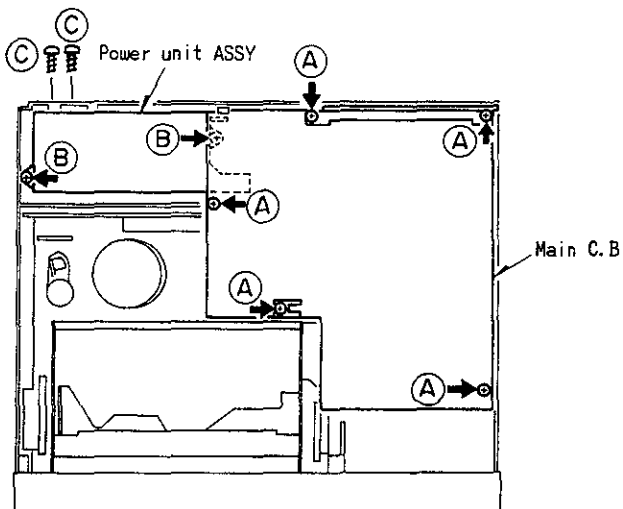

Fig-2

4. "FRONT LOADING ASSY" REMOVAL (See Figure-4)

- 1) Remove "Main belt".
- 2) Remove 4 screws (A).
- 3) Release the hooks on both sides and remove the "Front loading ASSY". (Since it is difficult to release these hooks, hold the front of the "Front loading ASSY" and shake it up and down to release them.)

5. "CASSETTE LOAD BRACKET ASSY" REMOVAL (See Figure-4)

- 1) Remove 1 screw (B).
- 2) Take off the "Cassette load bracket ASSY".

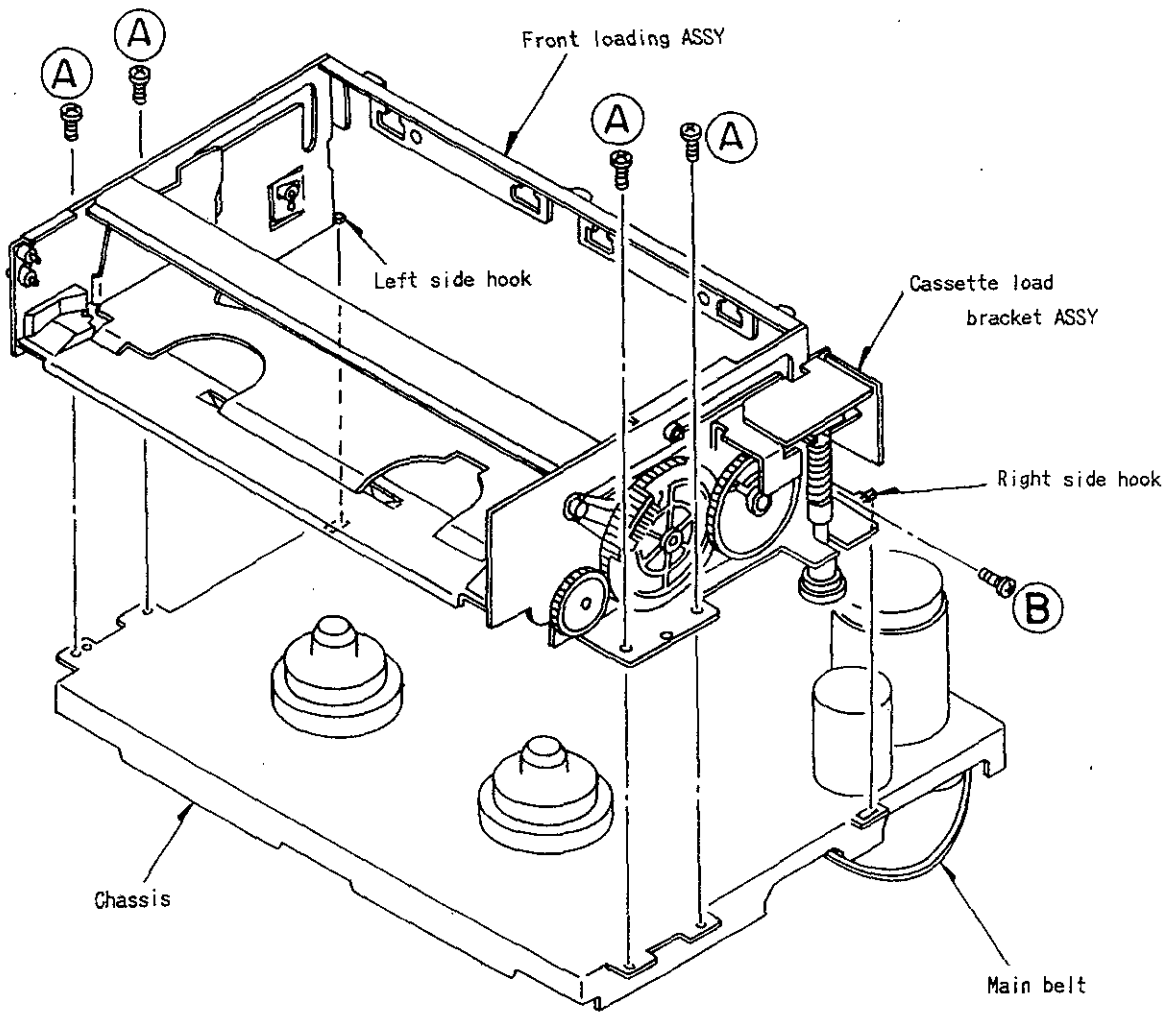

Fig-4



6. "PHOTO SENSOR ASSY" REMOVAL (See Figure-5)

1. "Lamp holder ASSY" Removal

1) Remove 1 screw (A), and take off the "T soft brake ASSY".

(At this time, never take off the "T-spring, soft brake arm".)

2) Release the "Lamp holder ASSY" from hook (a) of the chassis and turn it counterclockwise to remove it from the chassis.

2. "Switch C.B", "Sensor guide" and "End sensor C.B" Removal

1) Remove 1 screw (B) and take off the "Switch C.B".

2) Remove 1 screw (C) and take off the "Sensor guide".

3) Remove 1 screw (D) and take off the "End sensor C.B".

3. "Sensor guide" and "Start sensor C.B" Removal

1) Remove 1 screw (E) and take off the "Sensor guide".

2) Remove 1 screw (F) and take off the "Start sensor C.B".

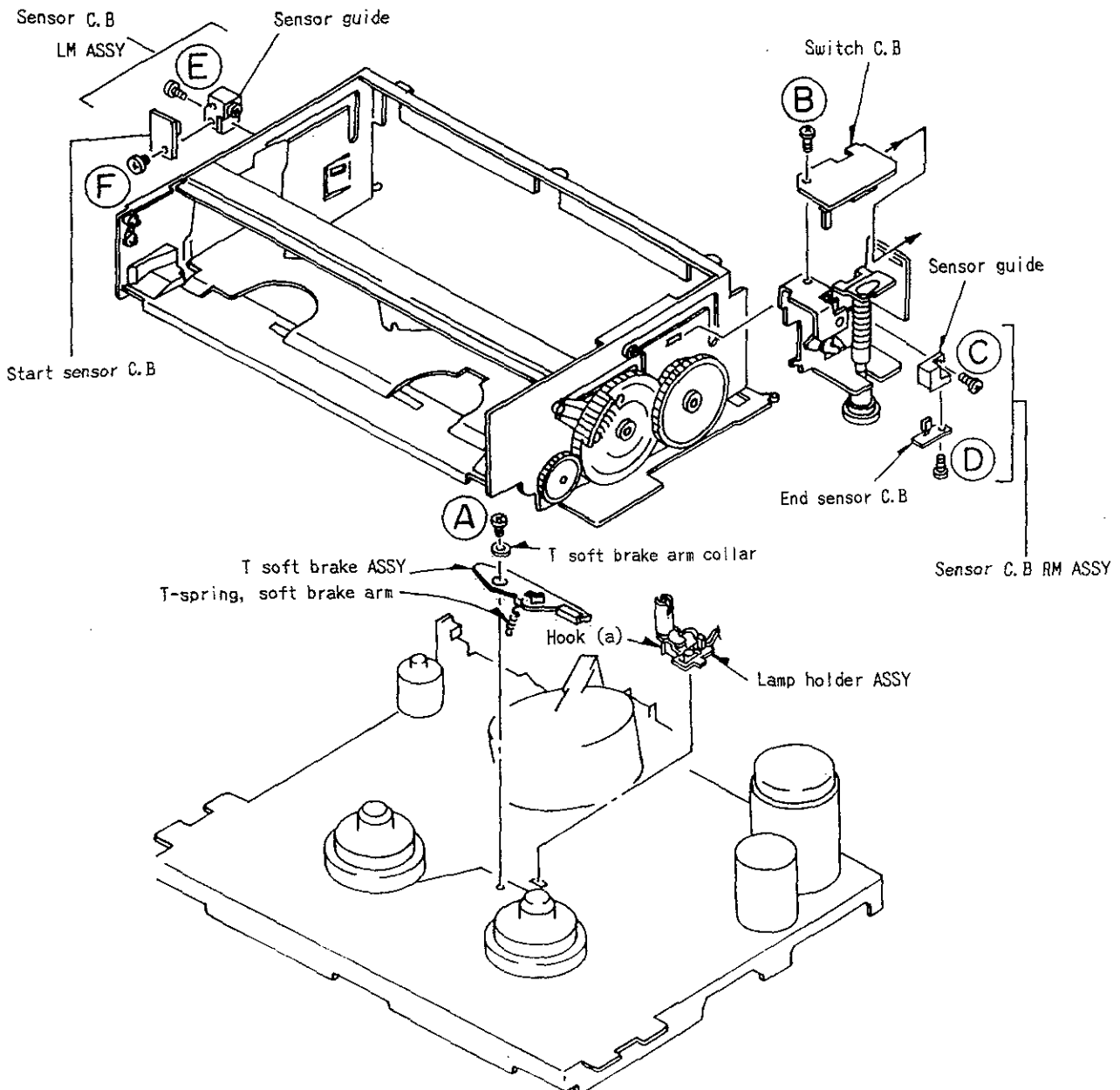

Fig-5

7. "FE PLATE" AND "ACE HEAD" REMOVAL (See Figure-6)

1. "FE plate" Removal

1) Remove Nut (A).

2) Take out the "Impedance roller" and pull up the "FE plate".

(Take care not to lose parts "Impedance roller", "Impedance roller sleeve", "Tape guide frange A", "Tape guide flange spring" and "Plane washer 3×8×0.5" at the time of the "FE plate" removal.)

3) Remove 1 screw (B) and take off the "Full erase head".

2. "ACE head" Removal

1) Remove 3 screws ((C)×1, (D)×1, (E)×1) and "Azimuth spring".

2) Remove "ACE head".

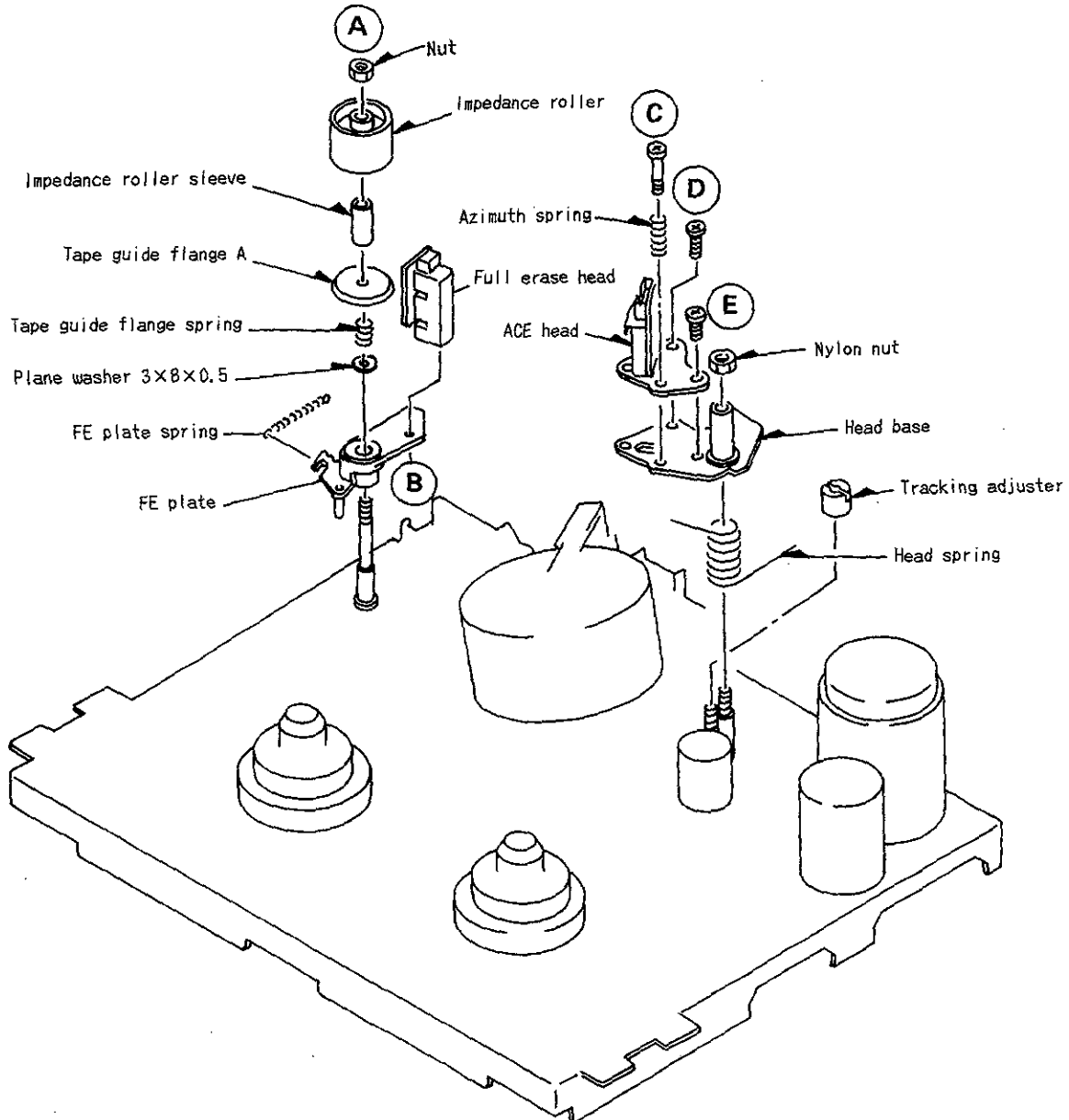

Fig-6

8. "GEAR HOLDER ASSY" REMOVAL (See Figure-7)

- 1) Remove the "Front loading ASSY".
- 2) Remove "Drive belt".
- 3) Remove Poly-Washer and "Middle pulley ASSY".
- 4) Remove Nylon-Washer (A) and take off the "Clutch ASSY".
- 5) Remove 1 screw (B) and 2 screws (C) and take off the "Gear holder ASSY".
- 6) Remove 1 screw (D) and take off the "T-spring, soft brake arm".
- 7) Take off the "T soft brake ASSY".
- 8) Remove 2 "E-Rings (E)" and take off the 2 "Reel drive gear".

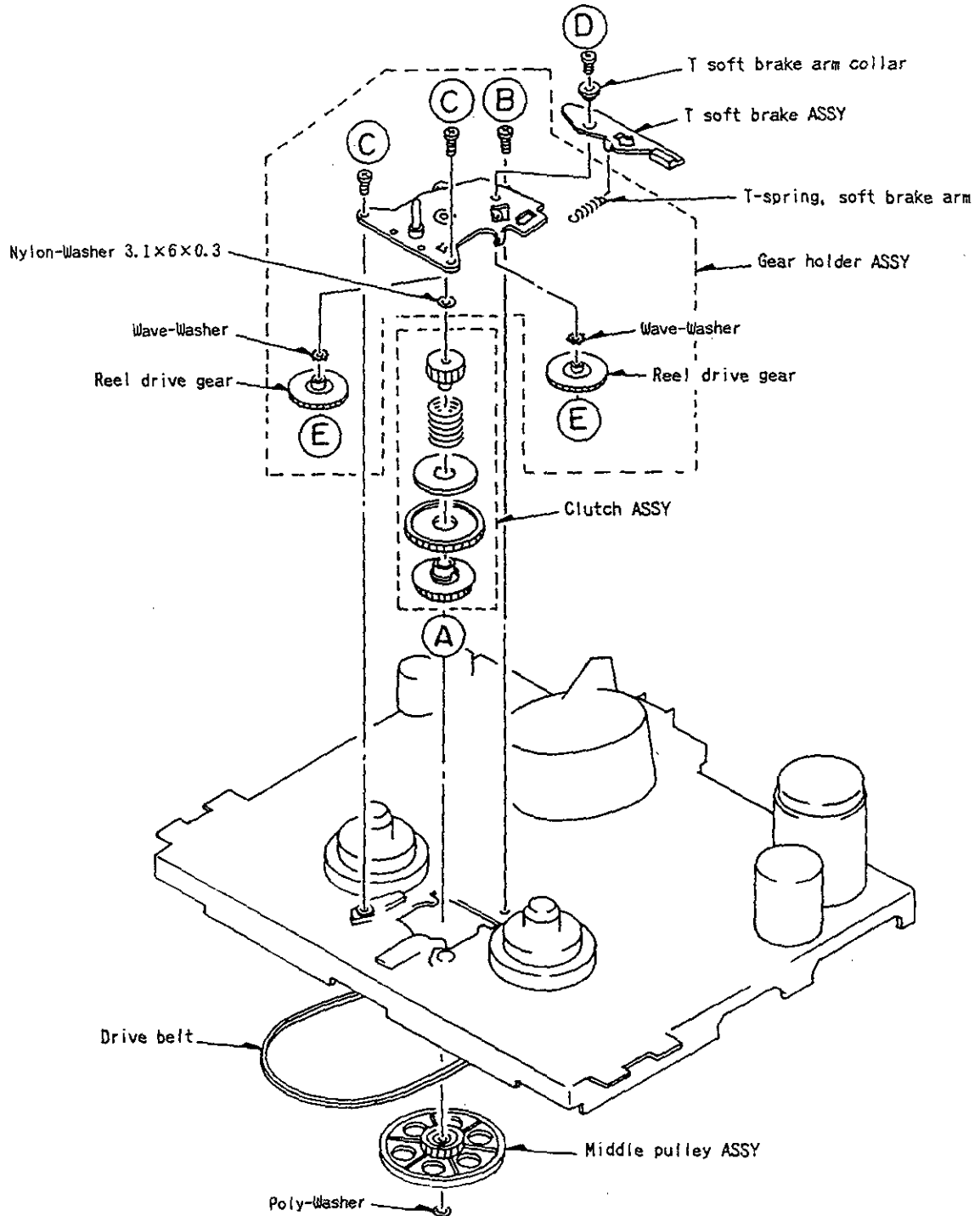

Fig-7

9. "BT BAND ASSY" AND "BT ARM SEMI ASSY" REMOVAL (See Figure-8)

- 1) Remove the "Front loading ASSY".
- 2) Remove Poly-Washer (A) and "BT actuate plate spring" from the "BT arm semi ASSY".
- 3) Remove 1 screw (B) and "Band holder spring".
- 4) Take off the "BT band ASSY" from the "BT arm semi ASSY".

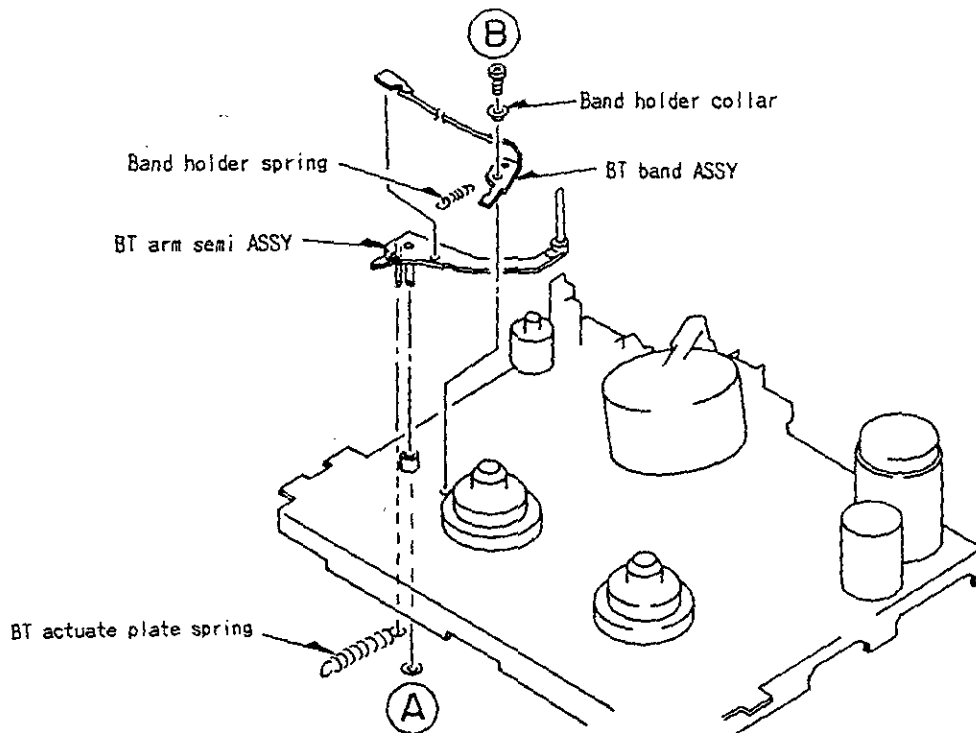

Fig-8

10. "REEL ASSY" REMOVAL (See Figure-9)

- 1) Remove the "Front loading ASSY", "Gear holder ASSY" and "BT band ASSY".
- 2) Remove 1 screw (A) and the "Back tension support".
- 3) Remove the 2 "Reel ASSY".

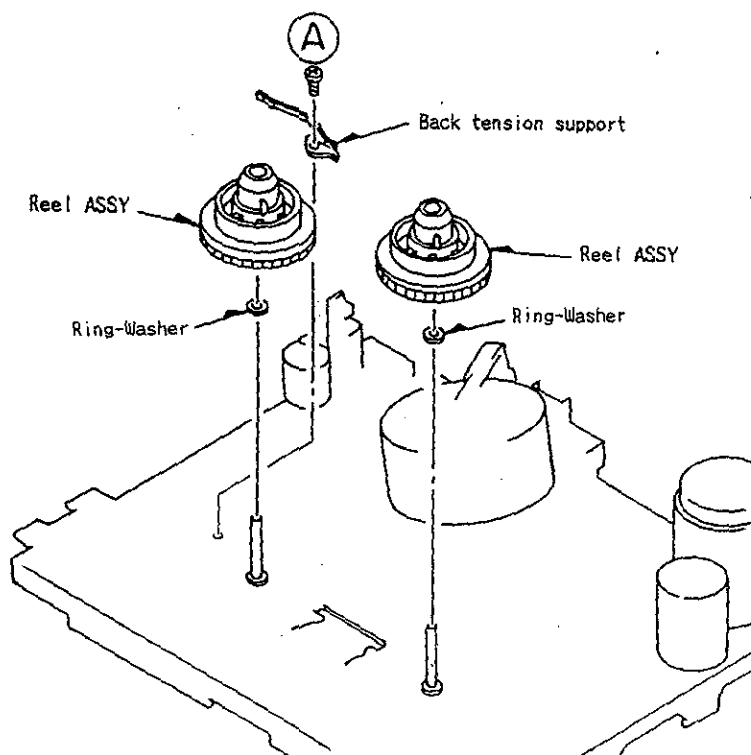

Fig-9

11. "CYLINDER ASSY" REMOVAL (See Figure-10)

- 1) Remove the "Front loading ASSY".
- 2) Pull out the "RELAY C.B-5" from the "Cylinder motor TM82".
- 3) Remove 1 screw (A) and take off the "Drum earth".
- 4) Remove 3 screws (B) and take off the "Cylinder ASSY".

≡Remarks≡

Take off the "Cylinder ASSY" carefully without any damage.

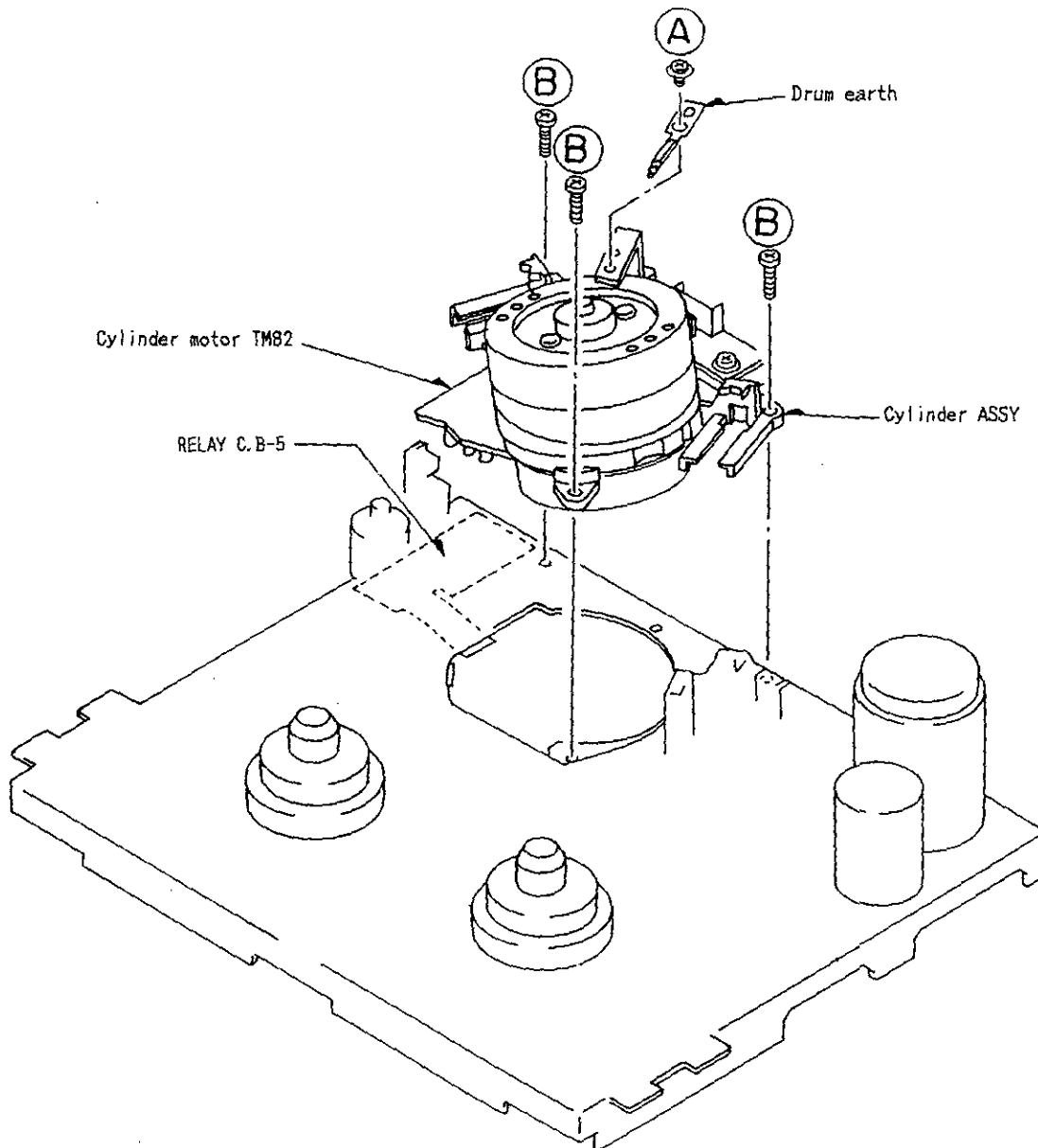

Fig-10

12. "UPPER DRUM" REMOVAL (See Figure-11)

- 1) Remove the "Front loading ASSY".
- 2) Remove 1 screw (A) and take off the "Drum earth bracket".
- 3) Remove 2 screws (B) and take off the "Upper drum".

≡Remark≡

1. Use gloves and do not touch the drum surface with bare fingers.
2. If the Video head is defective, replace the complete "Upper drum" with the Head.

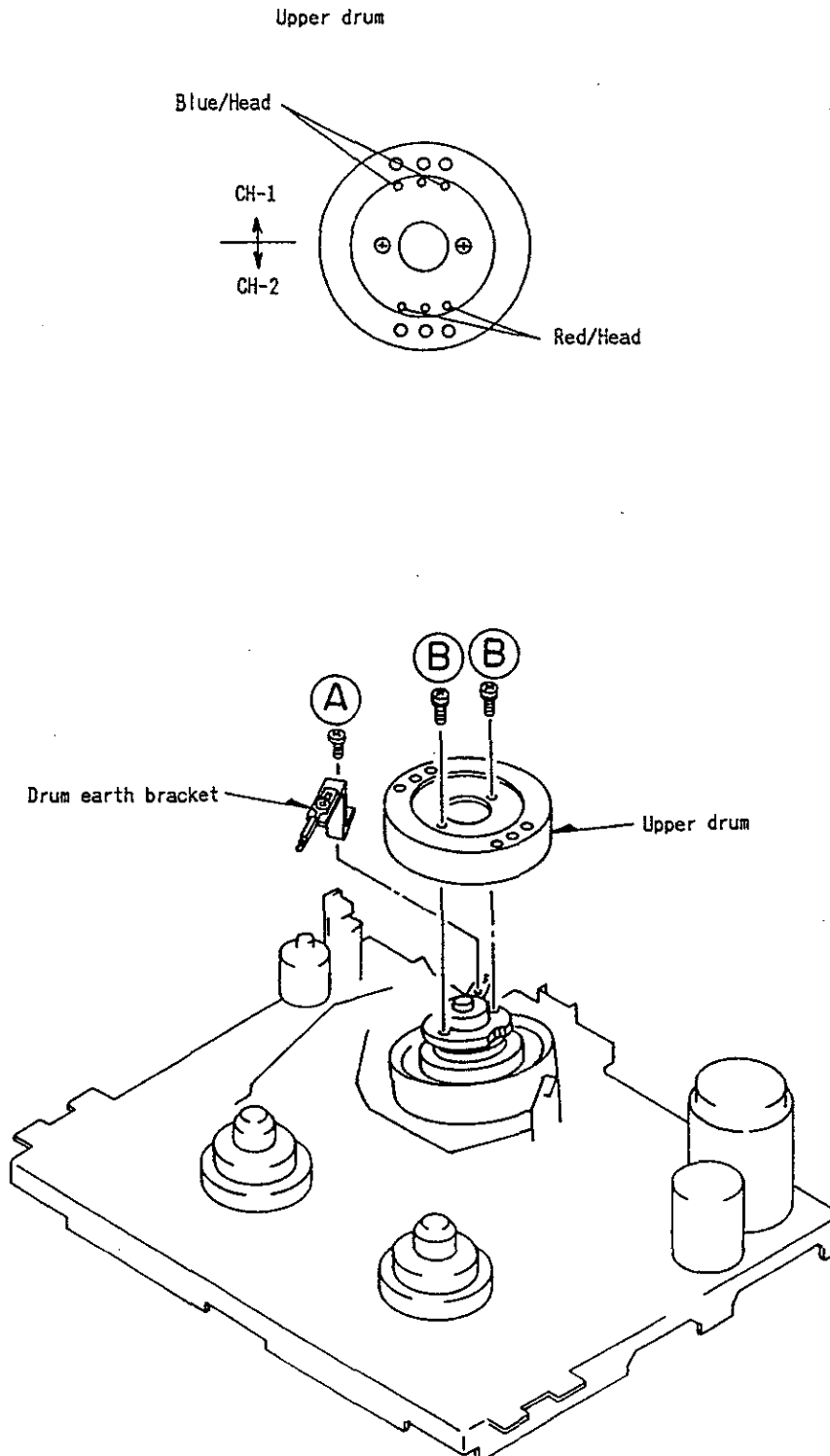

Fig-11

13. "CYLINDER MOTOR" REMOVAL (See Figure-12)

- 1) Pull out the "RELAY C.B-5" from the "Cylinder motor TM82".
- 2) Remove 2 screws (A) and take off the "Cylinder motor TM82".
- 3) Remove 3 screws (B) and take off the "Cylinder motor TM82".

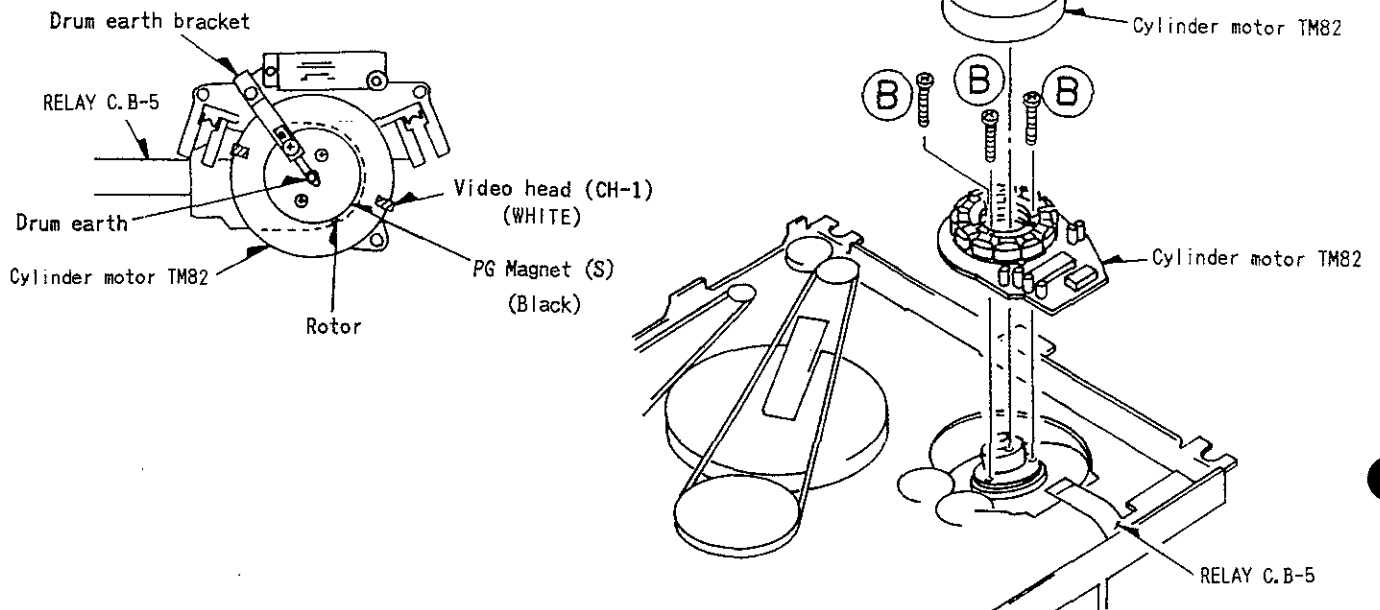

Fig-12

14. "CAPSTAN MOTOR ASSY" AND "LOADING MOTOR ASSY" REMOVAL (See Figure-13)

1. "Capstan Motor ASSY" Removal

- 1) Take off the "Drive belt" and "Main belt".
- 2) Remove 2 screws (A) and take off the "Capstan motor ASSY".

2. "LOADING MOTOR ASSY" Removal

- 1) Take off the "FL belt".
- 2) Remove 2 screws (B) and take off the "Loading motor ASSY".

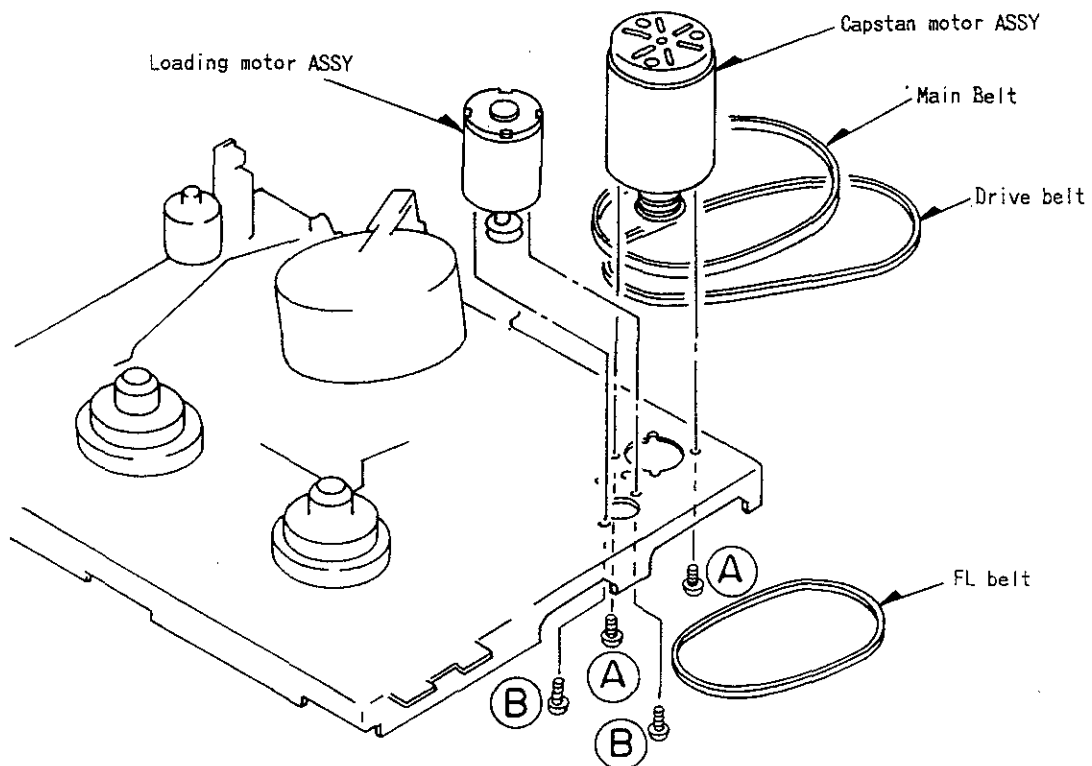

Fig-13

15. "LOADING GEAR" AND "LOADING CAM ASSY" REMOVAL (See Figure-14)

- 1) Take off the "Loading belt" from the "Loading pulley".
- 2) Remove Poly-Washer (A) and take off the "Loading pulley".
- 3) Remove Poly-Washer (B) and take off the "Loading gear".
- 4) Remove Poly-Washer (C) and take off the "Eject arm" and the "Brake actuate arm".
- 5) Remove 2 screws (D), and take off the "Loading lever reinforce plate" and the "Loading lever ASSY".
- 6) Take off the "Loading cam ASSY".

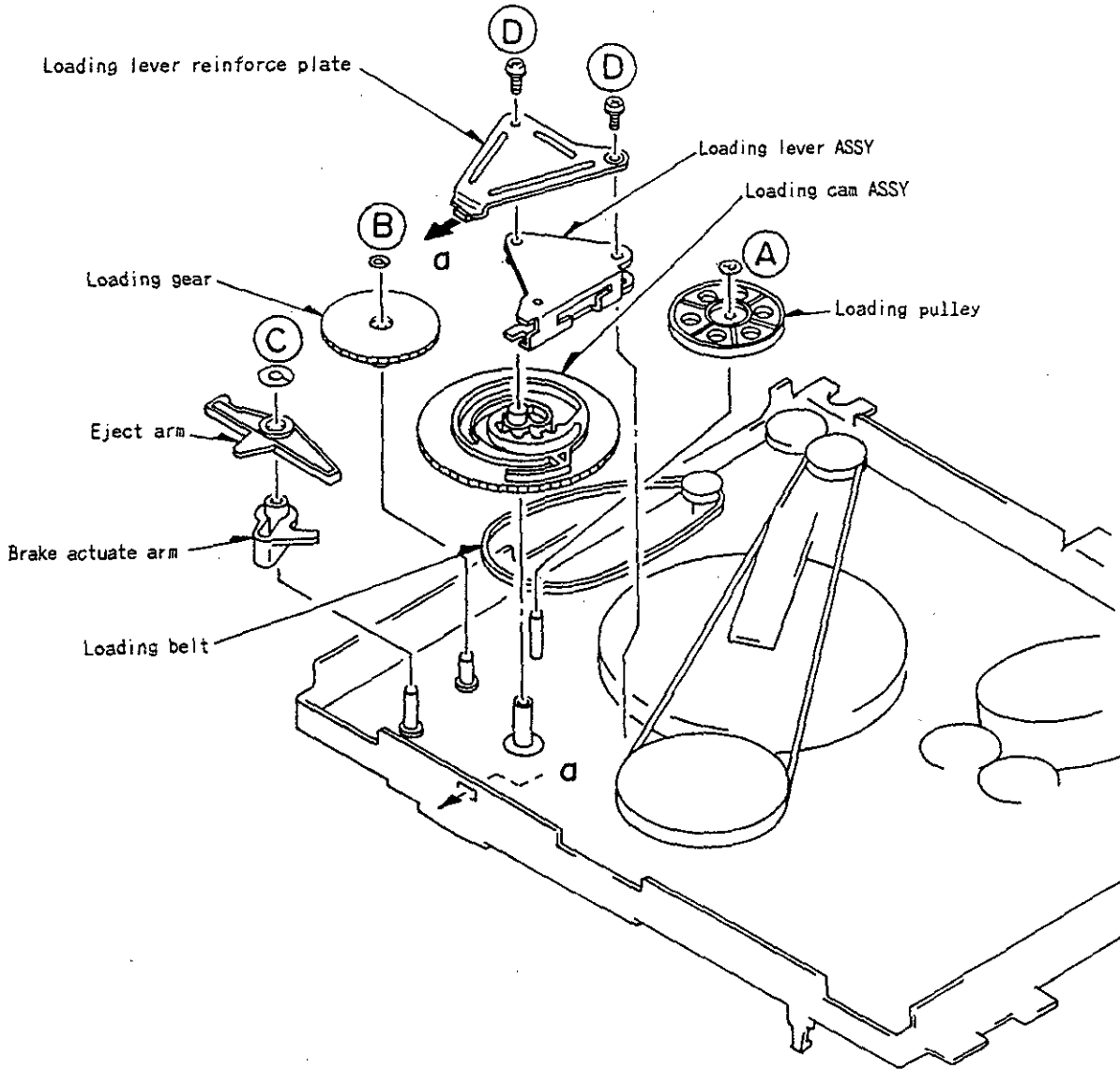

Fig-14



16. "FLYWHEEL CAPSTAN" REMOVAL (See Figure-15)

- 1) Remove the Nylon-Washer (A).
- 2) Take off the "Drive belt" and "Main belt".
- 3) Remove 2 screws (B) and take off the "FL angle ASSY".
- 4) Take off the "Flywheel capstan".

≡Remark≡

Do not miss the Poly-Washer (C) when pulling out the "Flywheel capstan".

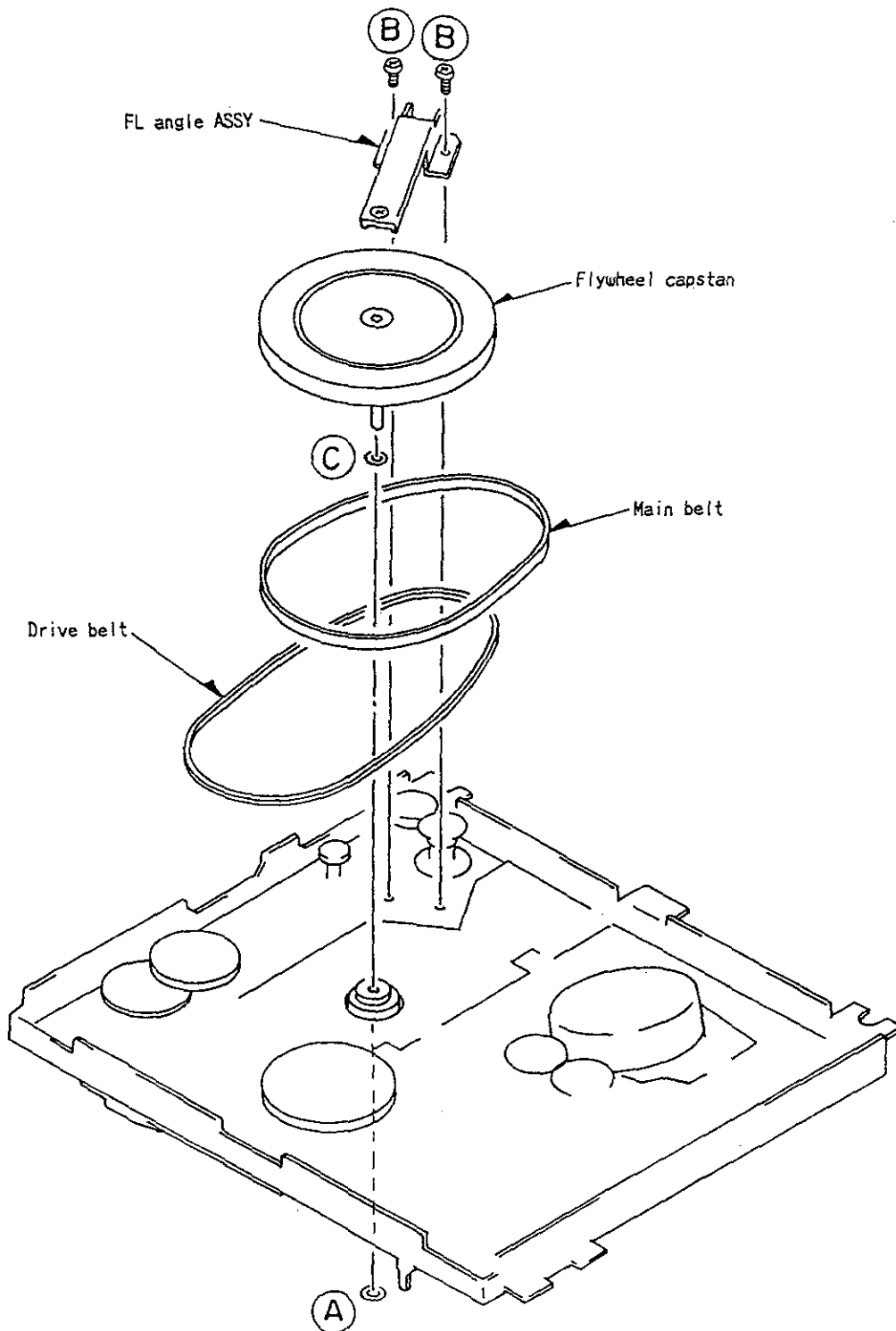

Fig-15

17. "REEL SENSOR" REMOVAL (See Figure-16)

1. Remove "Front loading ASSY" and the "Gear holder ASSY".
2. Remove "Reel ASSY".
3. Remove "Reel sensor".

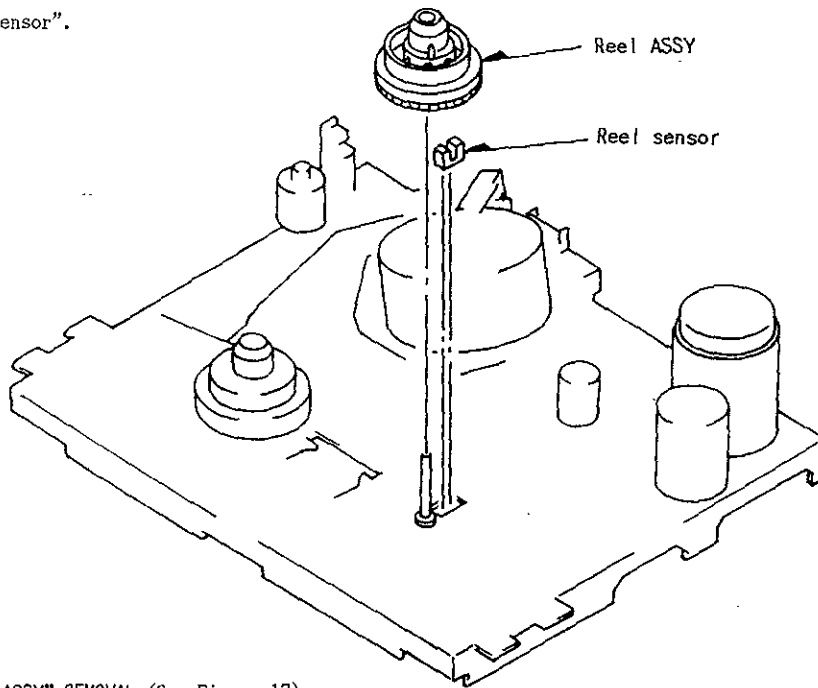

Fig-16

18. "LOADING BASE SEMI ASSY" REMOVAL (See Figure-17)

- 1) Remove "Cylinder ASSY", "BT arm semi ASSY", "BT band ASSY" and "Front loading ASSY".
- 2) Remove 1 screw (A) and "L gear plate collar", "L gear plate".
- 3) Remove 2 screws (B).
- 4) Take off the "Loading base semi ASSY".

≡Remark≡

When installing the "L gear plate", align markings (C) on the "T loading gear L" and "L gear plate".

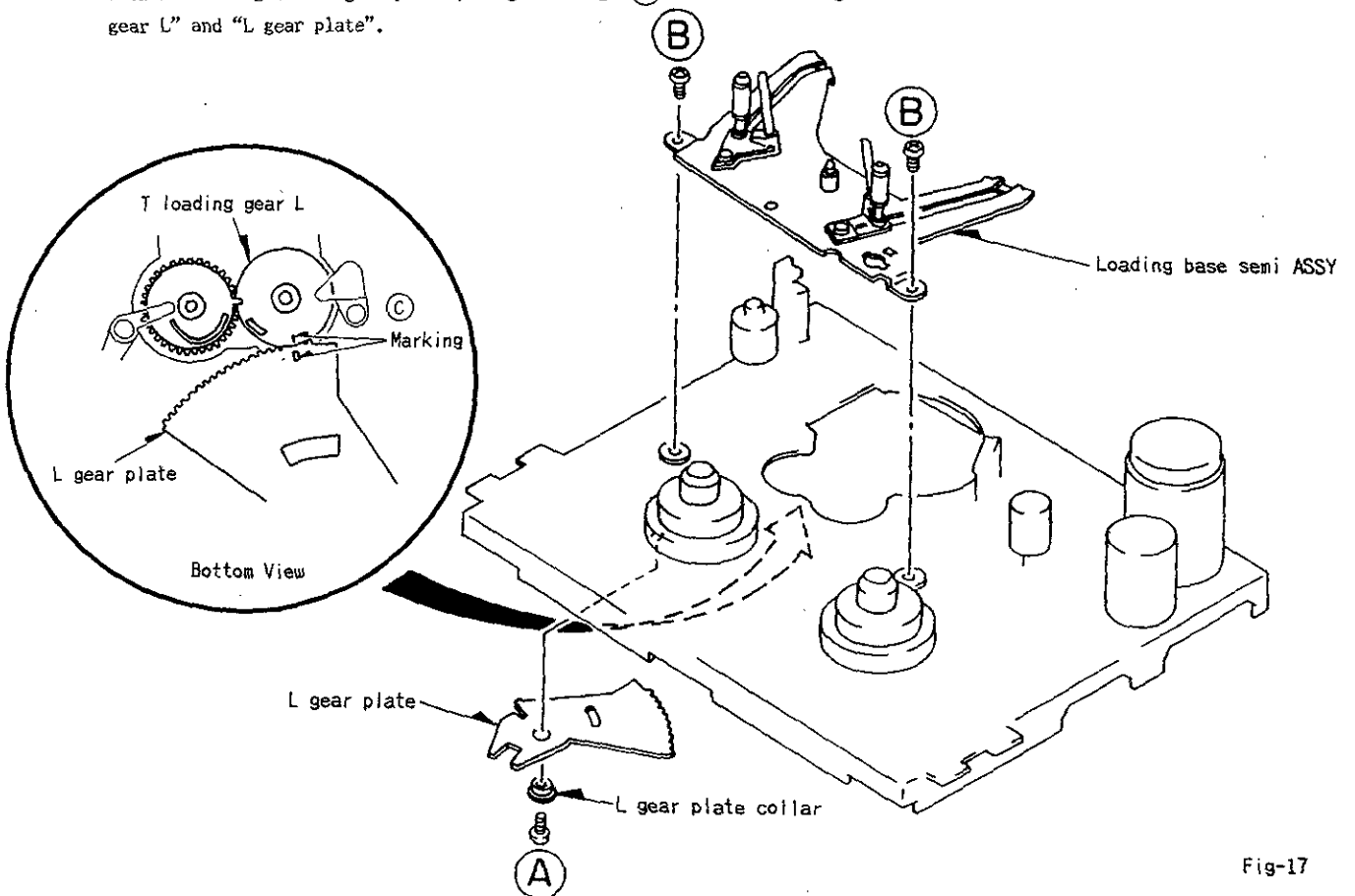

Fig-17

19. "WORMWHEEL ASSY" REMOVAL (See Figure-18)

1. Disassembly

- 1) Remove "Front loading ASSY".
- 2) Remove "Cassette load bracket ASSY".
- 3) Remove E-Ring (A).
- 4) Remove "Wormwheel ASSY". ("Wormwheel", "Friction spring", "Friction gear")

2. Assembly

- 1) Turn the "Lift gear R" fully counterclockwise.
- 2) Restore "Wormwheel ASSY" to the stud.

≡Remark≡

Match "Lift gear R" to the "Wormwheel hole" as illustrated.

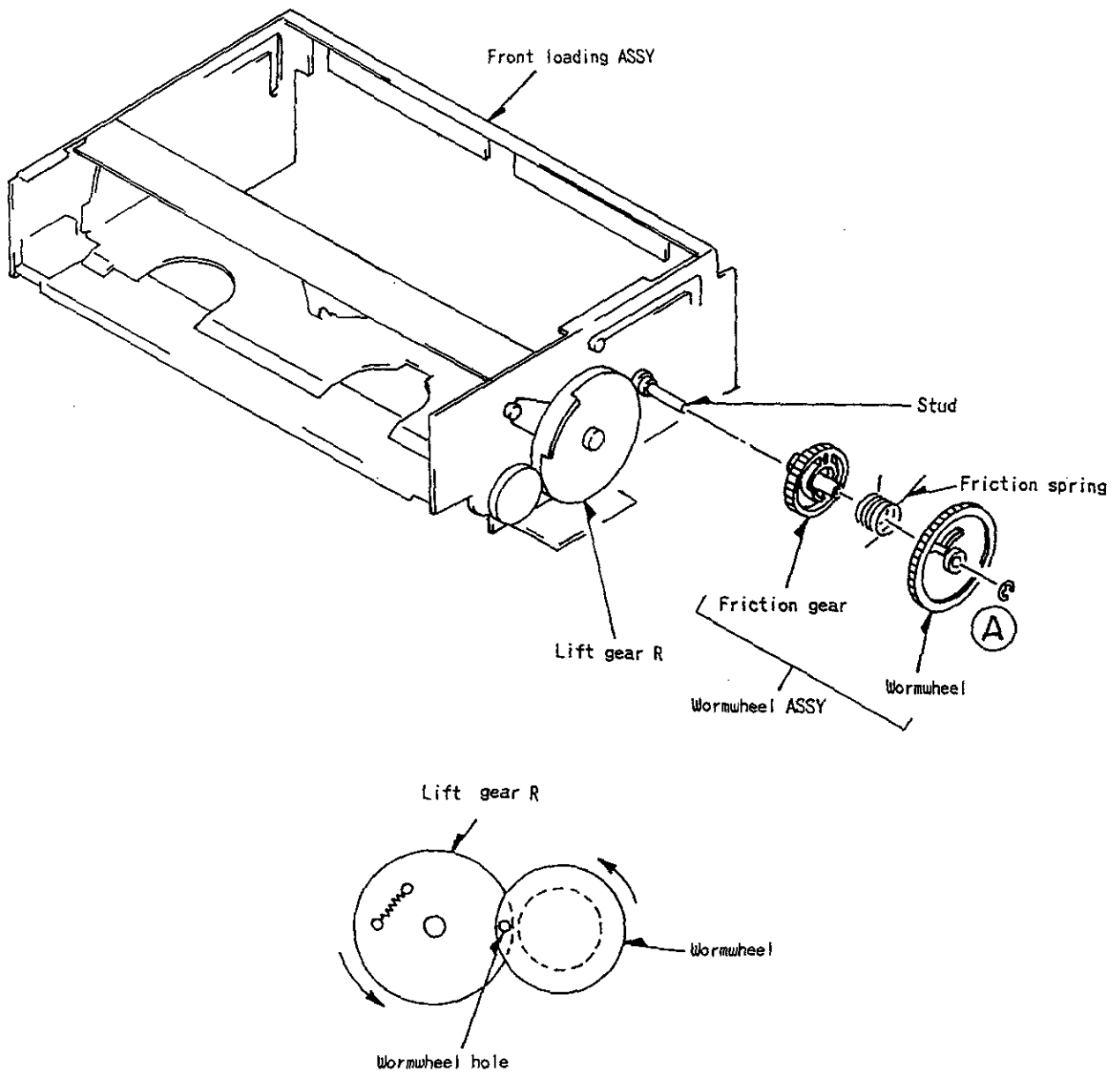

Fig-18

# ELECTRICAL MAIN PARTS LIST

## NOTE:

As regards the resistors and capacitors, refer to the circuit diagrams and the PCB assy drawings contained in this manual.

### COMBI VTSS COMPL PARTS LIST

REF. NO.	PARTS NO.	DESCRIPTION
	*9A02423640	COMBI VTSS PCB ASSY..MV-308
	*9A02530540	COMBI VTSS PCB ASSY..MV-307 (CONSISTS OF MAIN, SERVO/SYSCON, RELAY 1/2/3/4 PCB SECTION)
	*9A02528700	PCB, COMBI VTSS..MV-308/307 (CONSISTS OF VT-11, SS-11, CN-11, CN-12, 13, 14 PCB)
PCB-A.....MAIN PCB SECTION		
BT401	9A02449400	CONN ASSY, 2P TS-13
CN401	9A02448300	CONN, 9P 8283 V WHT
CN402	9A02439100	CONN, 7P 8283 V WHT
CN403	9A02439000	CONN, 4P 8283 V WHT
CN404	9A02448400	CONN, 8P TXL
D411, 412	9A02436600	DIODE, 1SS133
D801, 881	9A02436600	DIODE, 1SS133
DL461	9A02450500	DL, EFD-JF124A13F
FL411	9A02449900	FLTR, LPF 3M 7YCP
FL461	9A02450300	FLTR, LPF 1M
FL462	9A02449800	FLTR, BPF 4.43M AC-7
FL463	9A02451600	FLTR, SFS 5.06ME
IC401, 581	9A02446400	IC, LVA 522S
IC411	9A02446100	IC, LA7323
IC412	9A02446000	IC, LC8992
IC461	9A02446600	IC, LA7333
IC801	9A02447900	IC, LA7910
IC802	9A02455200	IC, UPC574J
IC803	9A02447800	IC, M4066BP
IC804	9A02446500	IC, PQ09R05
IC881	9A02449700	IC, UPD1730
IC882	9A02449600	IC, MSM16811
J401, 402	9A02450400	JACK, PIN 2-2
L401, 402	9A02440100	COIL, 100UH
L411, 412	9A02440100	COIL, 100UH
L415	9A02439800	COIL, 180UH LAL02
L416, 417	9A02451100	COIL, 68UH LAL02
L461, 801	9A02440100	COIL, 100UH
L462	9A02451400	COIL, 18UH J
L463	9A02451000	COIL, 3.3UH LAL02
L464	9A02451200	COIL, 27UH LAL02
L809-811	9A02440100	COIL, 100UH
L812	9A02451300	COIL, 47UH
L814	9A02440100	COIL, 100UH
Q411, 467	9A02455000	TRANSISTOR, DTA144ES

## COMBI VTSS PARTS LIST

REF. NO.	PARTS NO.	DESCRIPTION
Q413	9A02442400	TRANSISTOR, 2SA933S(SR)
Q414-416	9A02442300	TRANSISTOR, 2SC1740S(SR)
Q417-419	9A02442400	TRANSISTOR, 2SA933S(SR)
Q420	9A02436700	TRANSISTOR, DTC144ES
Q450	9A02442300	TRANSISTOR, 2SC1740S(SR)
Q451, 464	9A02442400	TRANSISTOR, 2SA933S(SR)
Q452, 581	9A02436700	TRANSISTOR, DTC144ES
Q462, 463	9A02442300	TRANSISTOR, 2SC1740S(SR)
Q465, 466	9A02442300	TRANSISTOR, 2SC1740S(SR)
Q468, 469	9A02442300	TRANSISTOR, 2SC1740S(SR)
Q598	9A02454900	TRANSISTOR, DTC114YS
Q599	9A02459000	TRANSISTOR, 2SA1048GR
Q801, 802	9A02442300	TRANSISTOR, 2SC1740S(SR)
Q805	9A02442400	TRANSISTOR, 2SA933S(SR)
Q808, 810	9A02442300	TRANSISTOR, 2SC1740S(SR)
RF801	9A02450900	RF MOD, S130A
SFR411	9A02454700	SFR, 10K DIA6 V
SFR412	9A02454700	SFR, 10K DIA6 V
SFR413	9A02454700	SFR, 10K DIA6 V
SFR414	9A02454500	SFR, 1K DIA6 V
SFR415	9A02454500	SFR, 1K DIA6 V
SFR416	9A02454600	SFR, 3.3K DIA6 V
SFR461	9A02454500	SFR, 1K DIA6 V
SFR801	9A02454600	SFR, 3.3K DIA6 V
TU801	9A02450700	TV TU, 4EA-721
VIF801	9A02450800	VIF PAC, 101A
X461	9A02458800	VIB, XTAL 4.43M
X801	9A02455500	VIB, CER 4.5MGW
	9A02450000	HT SINK, SV
PCB-B.....SERVO/SYSCON PCB SECTION		
CN201	9A02445800	CONN, 2P 1L-S
CN202	9A02447500	CONN, 5P HBRK 5S-2
CN211	9A02447100	CONN, 6P HBRK 6S-2
CN212	9A02447200	CONN, 7P HBRK 7S-2
CN213	9A02447400	CONN, 11P HBRK 11S-2
CN214	9A02447300	CONN, 9P HBRK 9S-2
CN215	9A02448500	CONN, 9P TXL V
D201-207	9A02436600	DIODE, 1SS133
IC201	9A02449500	IC, MB88525-205M
IC202	9A02454400	IC, PST 523D
IC203	9A02450100	IC, MN67481P
IC204, 205	9A02445900	IC, M5223L
IC206	9A02446200	IC, BA6219B
IC207	9A02450200	IC, HD404302A06P(MV-308 ONLY)
IC209	9A02448000	IC, TC4011BP
IC210	9A02446300	IC, BA6209-V3
L201	9A02451300	COIL, 47UH
L202	9A02451300	COIL, 47UH... (MV-308 ONLY)
L203, 204	9A02451500	COIL, 220UH EL0909
Q201, 202	9A02455100	TRANSISTOR, 2SA933S S

## COMBI VTSS PARTS LIST

REF. NO.	PARTS NO.	DESCRIPTION
Q204	9A02436700	TRANSISTOR,DTC144ES
Q205,206	9A02442300	TRANSISTOR,2SC1740S(SR)
Q207,208	9A02436700	TRANSISTOR,DTC144ES
Q209	9A02455100	TRANSISTOR,2SA933S S
Q210	9A02455000	TRANSISTOR,DTA144ES .....(MV-308 ONLY)
Q211	9A02436700	TRANSISTOR,DTC144ES .....(MV-308 ONLY)
Q212	9A02442300	TRANSISTOR,2SC1740S(SR) .....(MV-308 ONLY)
Q213	9A02436700	TRANSISTOR,DTC144ES
Q214	9A02436700	TRANSISTOR,DTC144ES .....(MV-308 ONLY)
Q215	9A02436700	TRANSISTOR,DTC144ES
Q216,217	9A02458900	TRANSISTOR,2SA1048Y
Q218	9A02436700	TRANSISTOR,DTC144ES
R254	Δ 9A02448100	R.,FUSE 100-1/4W
R266,282	Δ 9A02448200	R.,FUSE 3.3-1/2W
SFR201	9A02454800	SFR,220K DIA6 V TP
SFR202	9A02454800	SFR,220K DIA6 V TP
X201	9A02455400	VIB,CER KBR6.0MES
X202	9A02455300	VIB,CER KBR-4.0MES .....(MV-308 ONLY)

## PCB-F.....RELAY PCB-1 SECTION

CN206	9A02446900	CONN,11P 1L-SDD F
-------	------------	-------------------

## PCB-G.....RELAY PCB-2 SECTION

CN205	9A02446700	CONN,7P 1L-SDD F
-------	------------	------------------

## PCB-H.....RELAY PCB-3 SECTION

CN207	9A02446800	CONN,9P 1L-SDD F
-------	------------	------------------

## PCB-I.....RELAY PCB-4 SECTION

CN208	9A02447000	CONN,6P 1L-SDD M
-------	------------	------------------

## PWB HA COMPL PARTS LIST

REF. NO.	PARTS NO.	DESCRIPTION
PCB-C	*9A02423540	PRE AMP/AUDIO PCB ASSY(MV-308)
PCB-C	*9A02530440	PRE AMP/AUDIO PCB ASSY(MV-307)
	9A02439200	SHLD,RP
	9A02444800	PWB,HA-11 2M
	9A02445200	SHIELD,RP2
BT701	9A02439400	CONN ASSY,2P MH-12
CN601	9A02438900	CONN,6P 1L-SDD F
CN602	9A02439100	CONN,7P 8283 V WHT
CN701	9A02438600	CONN,5P 1L-S
CN702	9A02439000	CONN,4P 8283 V WHT
IC610	9A02438700	IC,LA7320
IC701	9A02438800	IC,BA7767AS
L601	9A02440000	COIL,10UH
L602	9A02440100	COIL,100UH
L630	9A02439700	COIL,47UH
L631	9A02439900	COIL,5.6UH LAL02
L633	9A02439600	COIL,15UH LAL02
L634	9A02439800	COIL,180UH LAL02
L701	9A02445000	COIL,18MH TL-8
L702	9A02436100	COIL,100UH
Q630-632	9A02442400	TRANSISTOR,2SA933S(SR)
Q633,634	9A02442300	TRANSISTOR,2SC1740S(SR)
Q701	9A02445100	TRANSISTOR,2SC3940(R)
Q702	9A02436700	TRANSISTOR,DTC144ES
SFR701	9A02442200	SFR,47K DIA6 V TP
T701	9A02439500	COIL,OSC BIAS-70K
WS601	9A02439300	F-CABLE, 5-2.0 160

## COMBI FR COMPL PARTS LIST

REF. NO.	PARTS NO.	DESCRIPTION
	*9A02423440	COMBI FR PCB ASSY...MV-308
	*9A02530340	COMBI FR PCB ASSY...MV-307 (CONSISTS OF TIMER, PWR.SW SECTION)

## PCB-D.....TIMER PCB SECTION

	9A02531200	PWB,COMBI FR 2M
	9A02435100	FILTER,FL
	9A02435200	HOLDER,FL
BT903	9A02435600	CONN ASSY,2P FF-11
C906	9A02438000	C.,CERA-CON 22P CH
CN901	9A02435400	CONN ASSY,9P TF-11
CN901,902	9A02434400	CONN,8P HBRK-8R-2
CN902	9A02435300	CONN ASSY,5P FP-11
CN903	9A02434200	CONN,6P R-FJ
D901-908	9A02436600	DIODE,1SS133

COMBI FR COMPL PARTS LIST

OTHERS PCB COMPL PARTS LIST

REF. NO.	PARTS NO.	DESCRIPTION
D910-920	9A02436600	DIODE,ISS133
D922-934	9A02436600	DIODE,ISS133
D936,937	9A02436600	DIODE,ISS133
D939	9A02436000	LED,LT3S47B...(MV-308 ONLY)
D940	9A02436600	DIODE,ISS133
D942	9A02436800	ZENER DIODE,HZ9C1L
FL901	9A02435500	FL,9-LT-20GK
IC901	9A02532700	IC,UPD75208CW-A83
IC902	9A02434100	IC,UNIT SBX1610-52
J901	9A02528400	JACK,PIN JPJ3844GOLD
L901,902	9A02436100	COIL,100UH
Q901-908	9A02436700	TRANSISTOR,DTC144ES
Q909	9A02436700	" ,DTC144ES..(MV-308 ONLY)
Q910	9A02436700	TRANSISTOR,DTC144ES
RV901	9A02434700	VOL,250KB PK09K113
RV902	9A02434600	VOL,10KB PK09K113
SW902-912	9A02528100	SW,TACT EVQ21409K
SW914-926	9A02528100	SW,TACT EVQ21409K
SW928,929	9A02528100	SW,TACT EVQ21409K
SW930	9A02435000	SW,SL 2-2-2...(MV-308 ONLY)
X901	9A02436900	VIB,CER KBR4.19MES
X902	9A02434900	VIB,XTAL32.768K5PPM

PCB-E.....POWER SW PCB SECTION

CN904	9A02434300	CONN,6P P-FJ
D909	9A02436600	DIODE,ISS133
D938	9A02435900	LED,SLZ-981C-02
SW901	9A02528100	SW,TACT EVQ21409K
X903	9A02434800	VIB,PIEZO PKM22EPP

PCB-I.....RELAY PCB-4 SECTION

CN208	9A02447000	CONN,6P 1L-SDD M
-------	------------	------------------

OTHERS PCB COMPL PARTS LIST

REF. NO.	PARTS NO.	DESCRIPTION
PCB-K.....BASE PCB SECTION		
PCB-K	*9A02763500	BASE PCB ASSY (W/MODE SW)
CP-1	9A02509300	PHOTO(REEL) SENSOR CN1385

REF. NO.	PARTS NO.	DESCRIPTION
PCB-L.....RELAY PCB-5 SECTION		
PCB-L	*9A02763600	RELAY PCB-5 ASSY
PCB-M.....RELAY PCB-6 SECTION		
PCB-M	*9A02763700	RELAY PCB-6 ASSY
PCB-N.....SWITCH PCB SECTION		
PCB-N	*9A02763800	SWITCH PCB ASSY (W/SW1,2,3)
PCB-O.....START SENSOR PCB SECTION		
PCB-O	*9A02763900	SENSOR PCB RM ASSY
PCB-P.....END SENSOR PCB SECTION		
PCB-P	*9A02764000	SENSOR PCB LM ASSY
PCB-Q.....LED PCB SECTION		
PCB-Q	*9A02764100	LED PCB ASSY (W/PCB-Q)
PCB-R.....ACE HEAD PCB SECTION		
PCB-R	*9A02764200	ACE HEAD PCB ASSY (W/PCB-R)
PCB-S.....ERASE HEAD PCB SECTION		
PCB-S	*9A02764300	ERASE HEAD PCB ASSY (W/PCB-S)

POWER UNIT PARTS LIST

REF. NO.	PARTS NO.	DESCRIPTION
*9A02423340 POWER UNIT PCB ASSY (CONSISTS OF POWER 1, 2, 3 SECTION)		
PCB-T POWER PCB-1 SECTION		
C101	Δ 9A02428100	C., AC250V 0.22MF
F101	Δ 9A02430500	FUSE, 1.6A 250V
J101	Δ 9A02429800	AC JACK, CCT-9302-0101
L101	Δ*9A02431000	COIL, ELF-18D290A
PCB-U POWER PCB-2 SECTION		
C102-1	9A02433300	C., 4700PF AC250V
C104	9A02428300	C., 400V82MF
C105	9A02428400	C., 630V0.047MF
C106	9A02428500	C., 1KV100PF
C107	9A02428600	C., 400V1MF
CON101	9A02764400	CONNECTOR, 9P
CON102	9A02764500	CONNECTOR, 8P
CON201	9A02764600	CONNECTOR, 4P
D101	9A02429900	DIODE, SIWBA60
D102	9A02427300	DIODE, 1SS202(1)-T1
D103	9A02430000	DIODE, HZ 6.2V
D201, 202	9A02430100	DIODE, S3LA20-04P15
D203	9A02430200	DIODE, DINL-20-4070
D205	9A02430300	DIODE, HZ24PB-TK
HIC101	9A02430600	HIC, MA2830 F4005
IC201	9A02430700	IC, AN1431T-TA
IC203	9A02430800	IC, AN78M05FA
IC204	9A02430900	IC, AN78M05R-A
L201, 202	9A02431100	COIL, RD0807A40
PC101	9A02431200	PHOTO, ON3171
Q201	9A02427900	TRANSISTOR, 2SB733K3-T
Q202	9A02431300	TRANSISTOR, UN4211-TA
Q205, 206	9A02431300	TRANSISTOR, UN4211-TA
R101	9A02431500	R., METAL 2.2 3W
R102	9A02431600	R., METAL 47K 3W
R103	9A02431700	R., 510K 1/2W
R104	9A02431800	R., 100K 1/4W
R105	9A02431900	R., METAL 27 1W
R106	9A02432000	R., METAL 39 1W
R107	Δ 9A02427800	R., FUSE 120 1/2W
R203	9A02427500	R., METAL 5.6K 1/4W
R205	9A02427600	R., METAL 1.5K 1/4W
R214	9A02427400	R., METAL 820 1W
SFR201	9A02433000	SFR, 500 1/10W
T101	Δ 9A02433100	TRANS, TS29K 21V

POWER UNIT PARTS LIST

REF. NO.	PARTS NO.	DESCRIPTION
PCB-V POWER PCB-3 SECTION		
D301	9A02427300	DIODE, 1SS202(1)-T1
D302	9A02427700	DIODE, RD2.7ESB2-T1
D303, 305	9A02430200	DIODE, DINL-20-4070
D304	9A02430400	DIODE, RD47EB-T1
PIN101	- - - -	CONNECTOR, 5P
PIN301	- - - -	CONNECTOR, 4P
Q301	9A02431400	TRANSISTOR, 2SC4148
Q302	9A02428000	TRANSISTOR, 2SC2002
T301	9A02433200	TRANS, F5M-89057

# PRACTICAL SERVICE FIGURE

## Output Level

Video (Impedance) :  $1.0 \pm 0.2V_{p-p}$  ( $75\Omega \pm 20\%$ , Unbalance)

Audio (Impedance) :  $-8 \pm 3dB$  (Less than  $3.3k\Omega$ )

RF Modulated (Impedance):  $75 \pm 3dB \mu V$  ( $75\Omega$ , Unbalance)

## Input Level

Video (Impedance) :  $0.5V \sim 2.0V \pm 0.5V_{p-p}$  ( $75\Omega \pm 20\%$ , Unbalance)

Audio (Impedance) :  $-10 \pm 3dB$  (More than  $47k\Omega$ )

## TV channels received

### HV-G55

Desti- nation	Signal format		VHF		UHF	Remarks MHz
	VHF	UHF	L	H		
AGPS E	B	G	E2-E4 S1-S2	E5-E12 S3-S20	21-69	Meets FTZ Specifi- cations VIF 38.9 SIF 33.4
IP K	-	I	X	X	21-69	39.5 33.5
GPS E	B	G	I1-E4	E5-E12	21-61	VIF 38.9 SIF 33.4

### HV-G53

Desti- nation	Signal format		VHF		UHF	Remarks MHz
	VHF	UHF	L	H		
AGPS E	B	G	E2-E4	E5-E12 S1-S20	21-69	Meets FTZ Specifi- cations VIF 38.9 SIF 33.4

### HV-G51

Desti- nation	Signal format		VHF		UHF	Remarks MHz
	VHF	UHF	L	H		
GPS E	B	G	I1-E4	E5-E12	21-61	VIF 38.9 SIF 33.4

### HV-G50

Desti- nation	Signal format		VHF		UHF	Remarks MHz
	VHF	UHF	L	H		
GPS H	B	G	I1-E4	E5-E12	21-69	VIF 38.9 SIF 33.4
DIP H	D	K	1-5	6-12	13-57	VIF 38.0
		I	2-4	5-12	21-69	SIF 31.5 D/K (32.0) (I)

Tuner AGC :  $72 \pm 3dB$  (VHF, UHF)

## S/N Ratio

Video (SP mode) : (Test tape MVP-08(PB), MVP-09(PB), TDK HS-120(R/P))

Signal	PB	R/P
Y-Signal	More than 42dB	More than 44.5dB
Chrominance -Signal(AM)	More than 38dB	More than 42dB
Chrominance -Signal(PM)	More than 36dB	More than 38dB

Audio (SP mode) : More than 40dB

Audio Frequency Response: 200Hz~6kHz ( $\pm 4dB$ )

(SP mode,

Test tape A-BEX TPV-160S)

Horizontal Resolution : More than 230 lines (PB., R/P)

(Test tape TTV-06T)

Erase Ratio : More than 55dB

Bias Frequency :  $70kHz \pm 10\%$

Tape speed :  $23.39mm/sec \pm 0.5\%$

(SP mode)

Wow & Flutter : Less than 0.4%

(Test tape TTV-P5,

CCIR WTD)

F.F time : Less than 290sec (E-240)

REW time : Less than 290sec (E-240)

Back tension :  $46.5 \pm 12g-cm$

Loading : Less than 3sec

Unloading : Less than 3.5sec





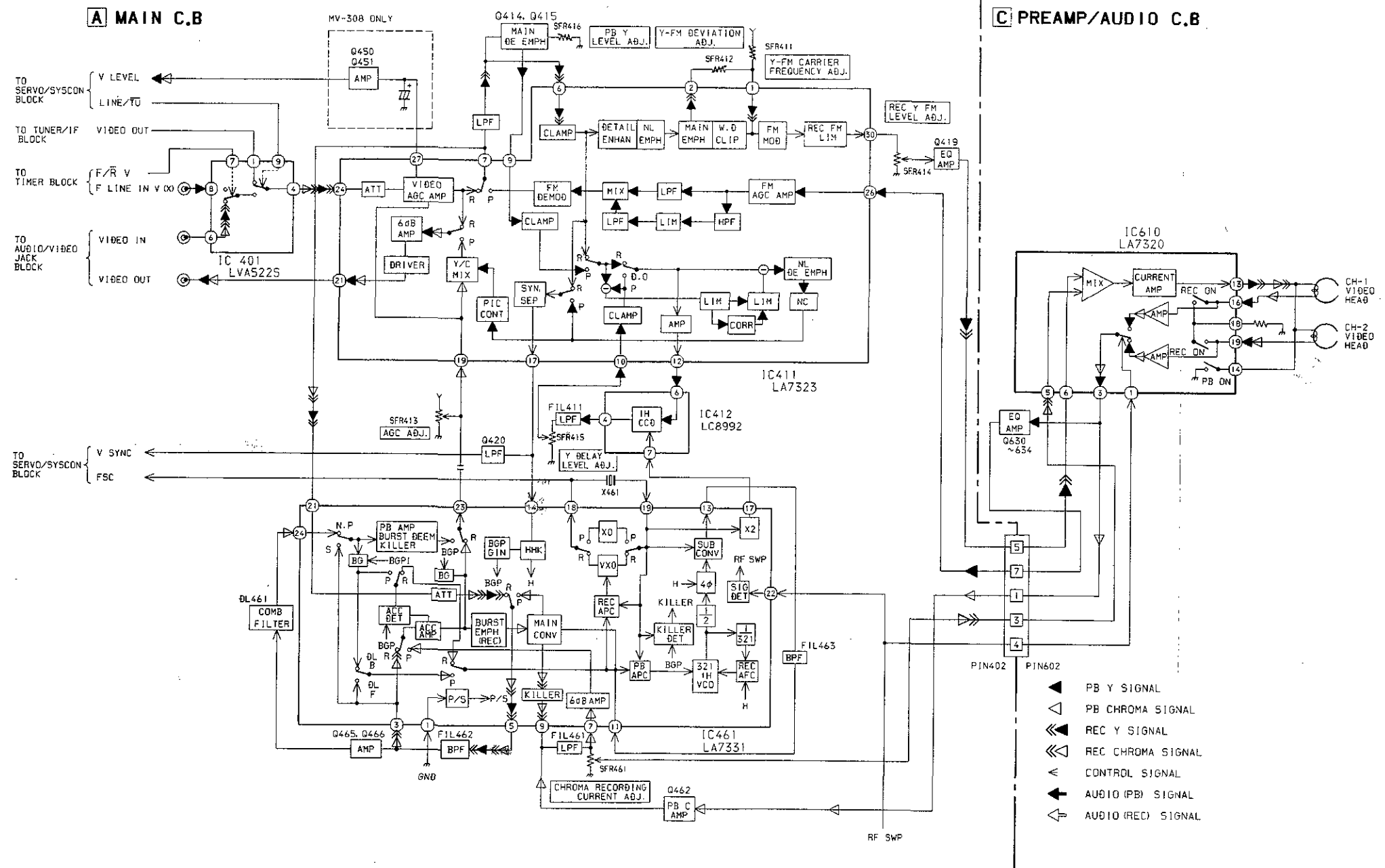

**A MAIN C.B.**

**C PREAMP/AUDIO C.B.**

- ▲ PB Y SIGNAL
- △ PB CHROMA SIGNAL
- ◀ REC Y SIGNAL
- ◀◀ REC CHROMA SIGNAL
- ◀ CONTROL SIGNAL
- ◀ AUDIO (PB) SIGNAL
- ◀ AUDIO (REC) SIGNAL

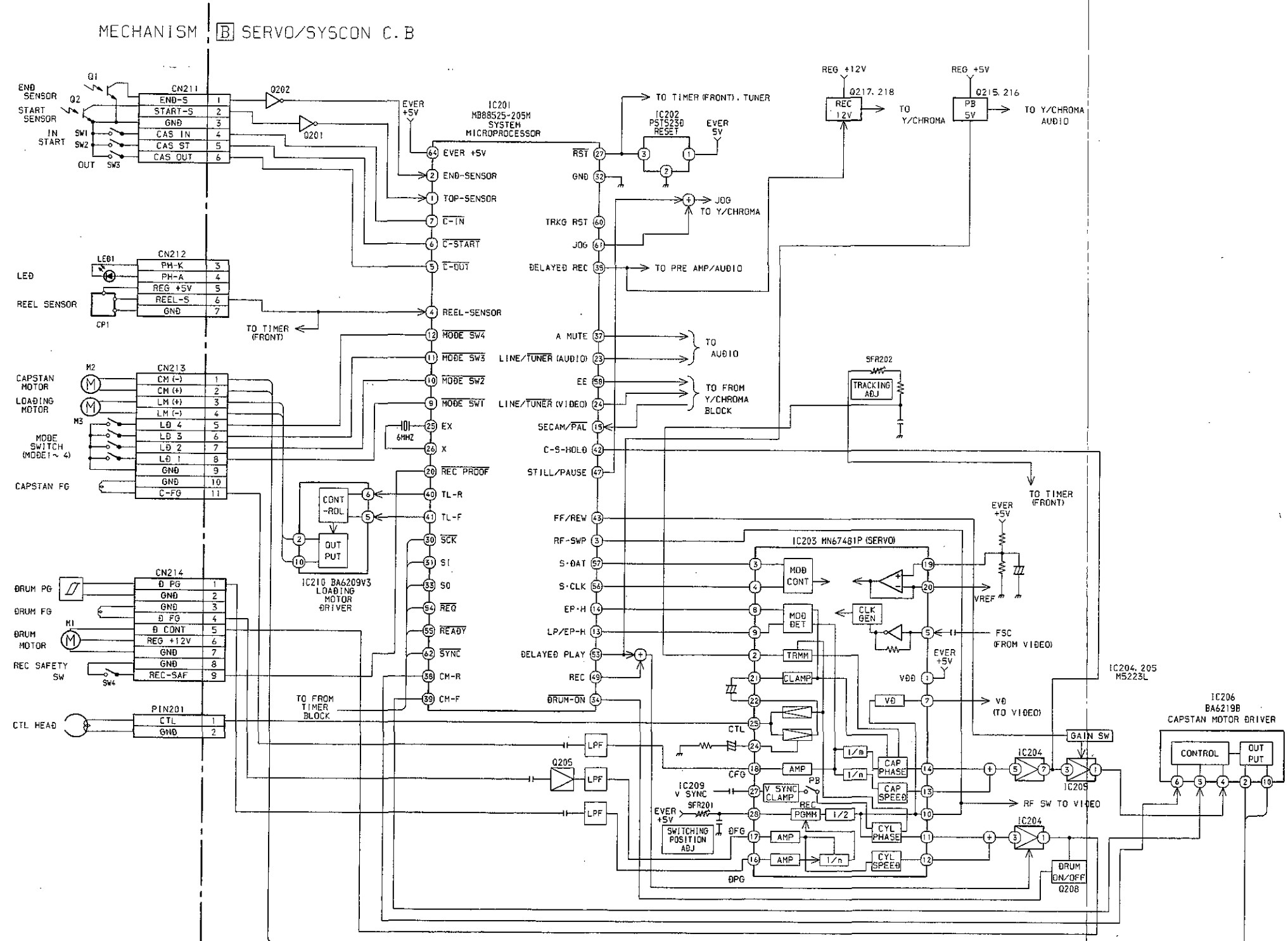

BLOCK DIAGRAM-5(TUNER)

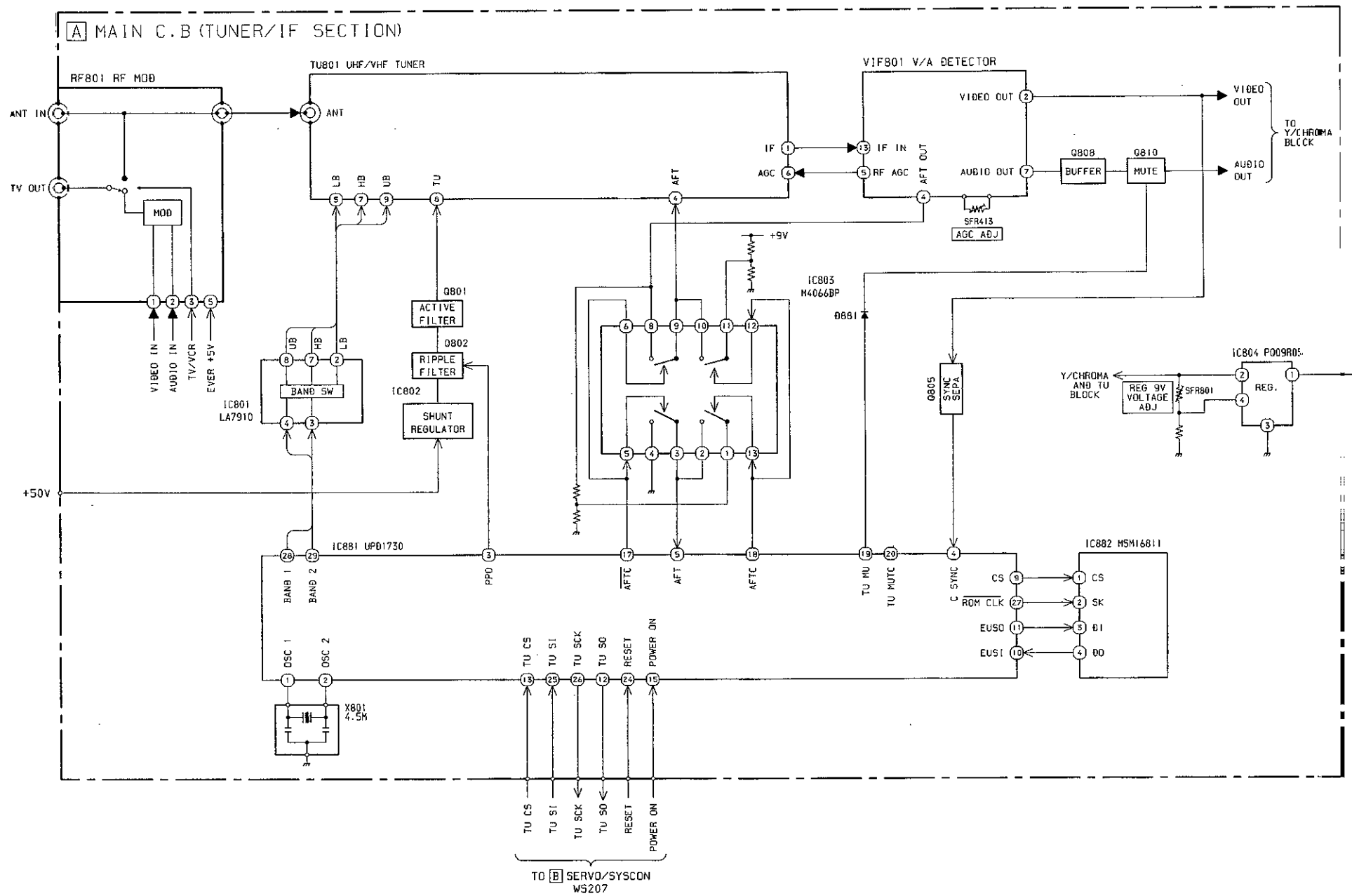

BLOCK DIAGRAM-4(SYSTEM CONTROL)

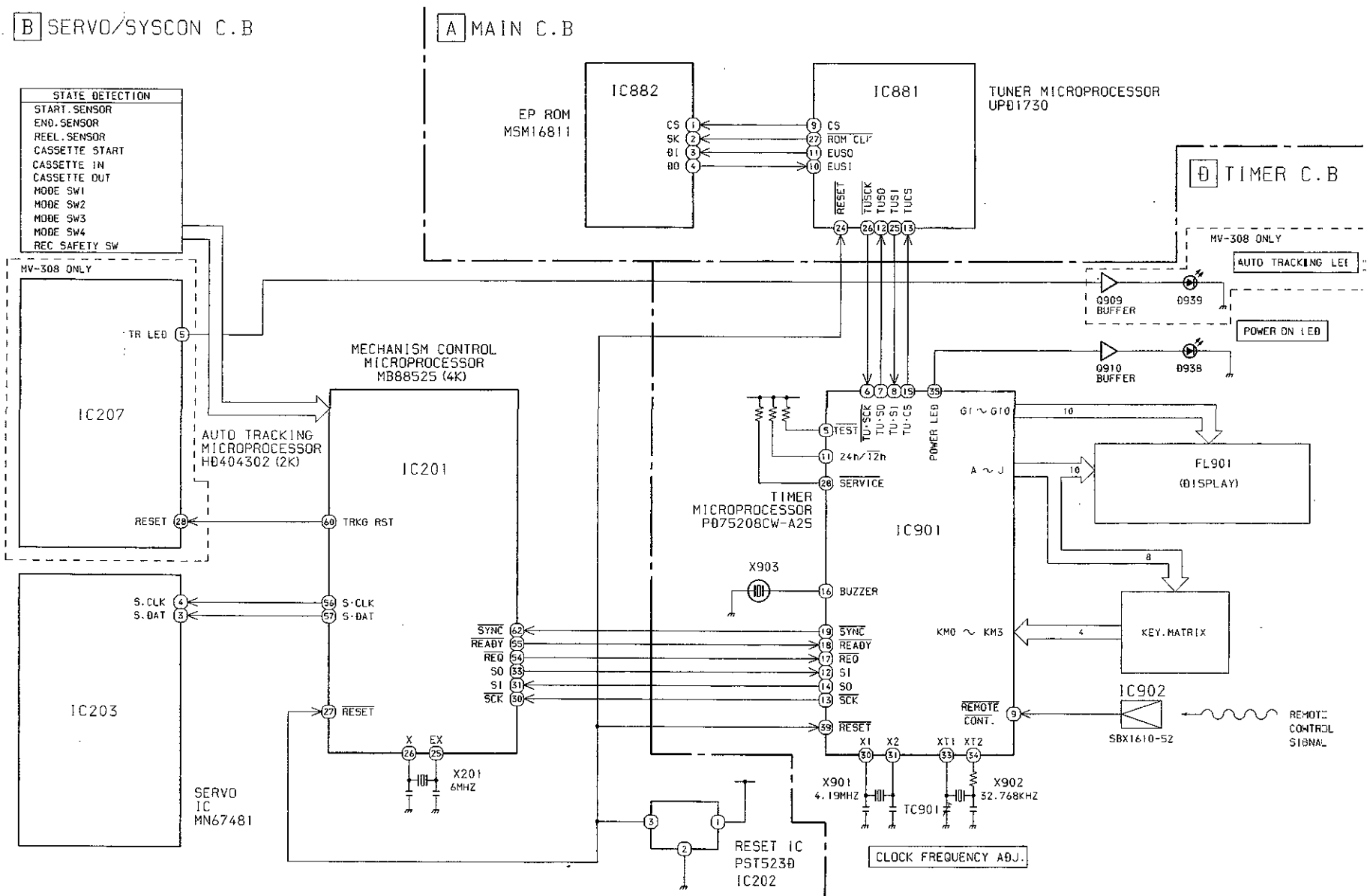

BLOCK DIAGRAM-6(AUDIO/POWER UNIT)

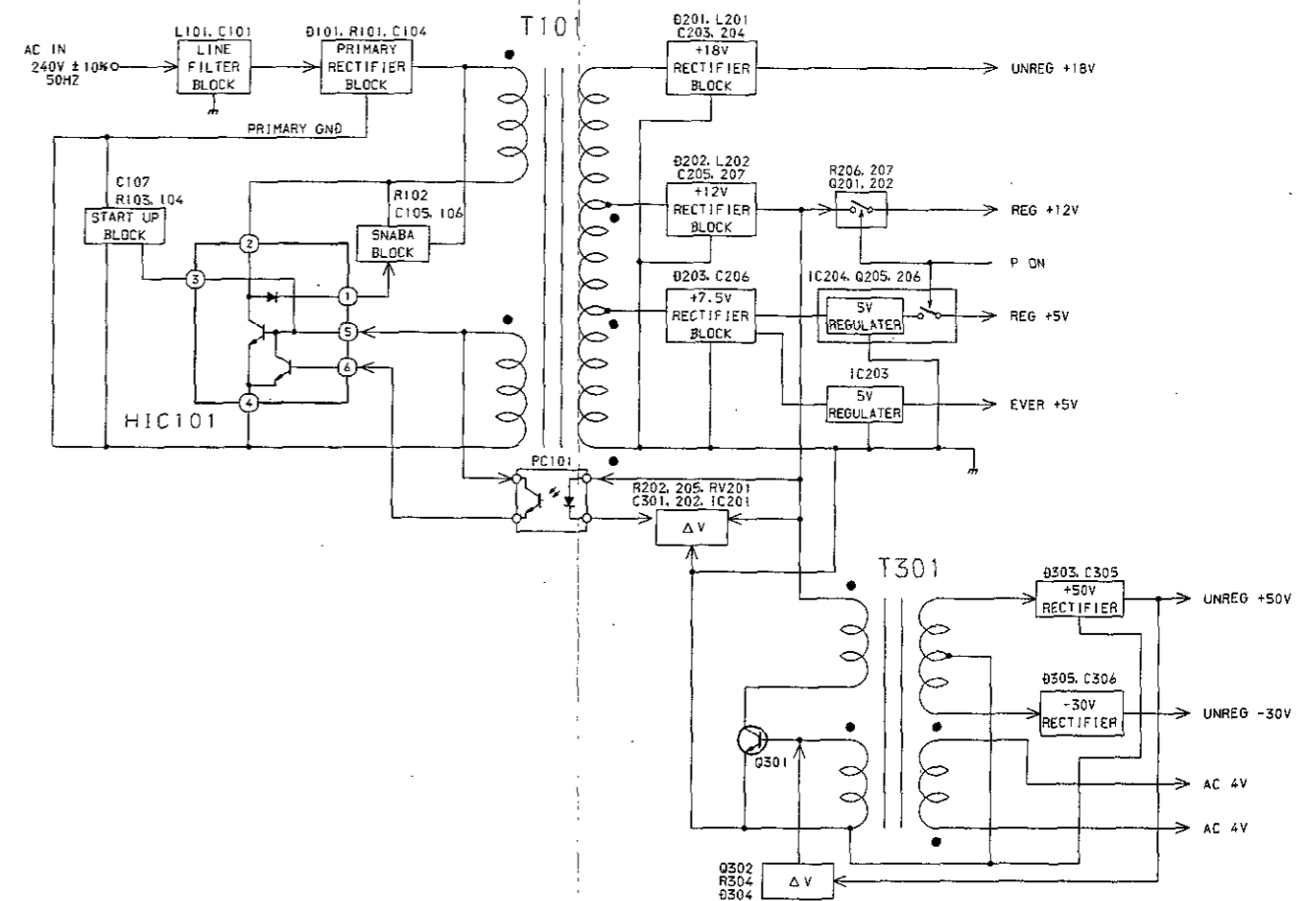
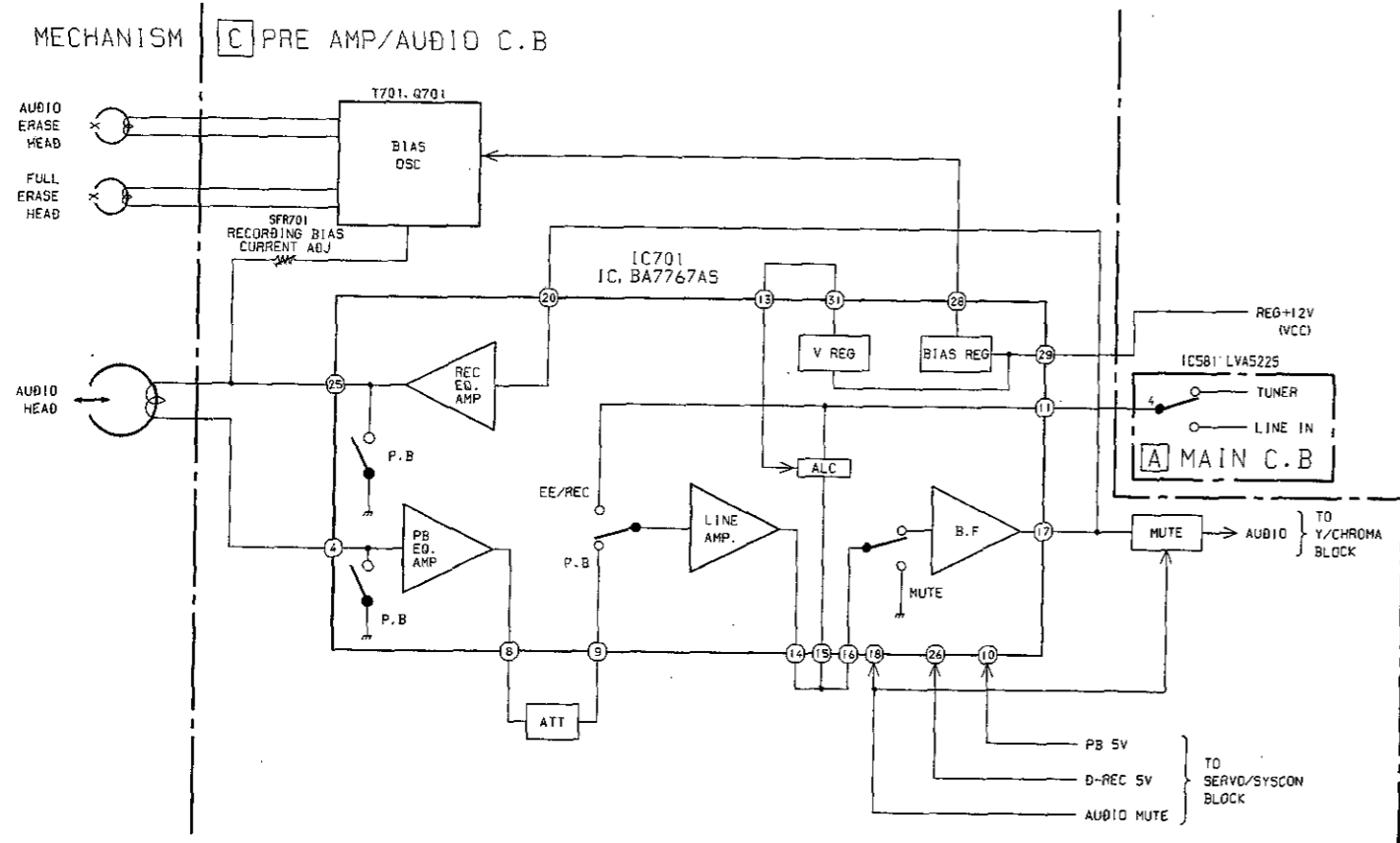

WIRE HARNESS DIAGRAM

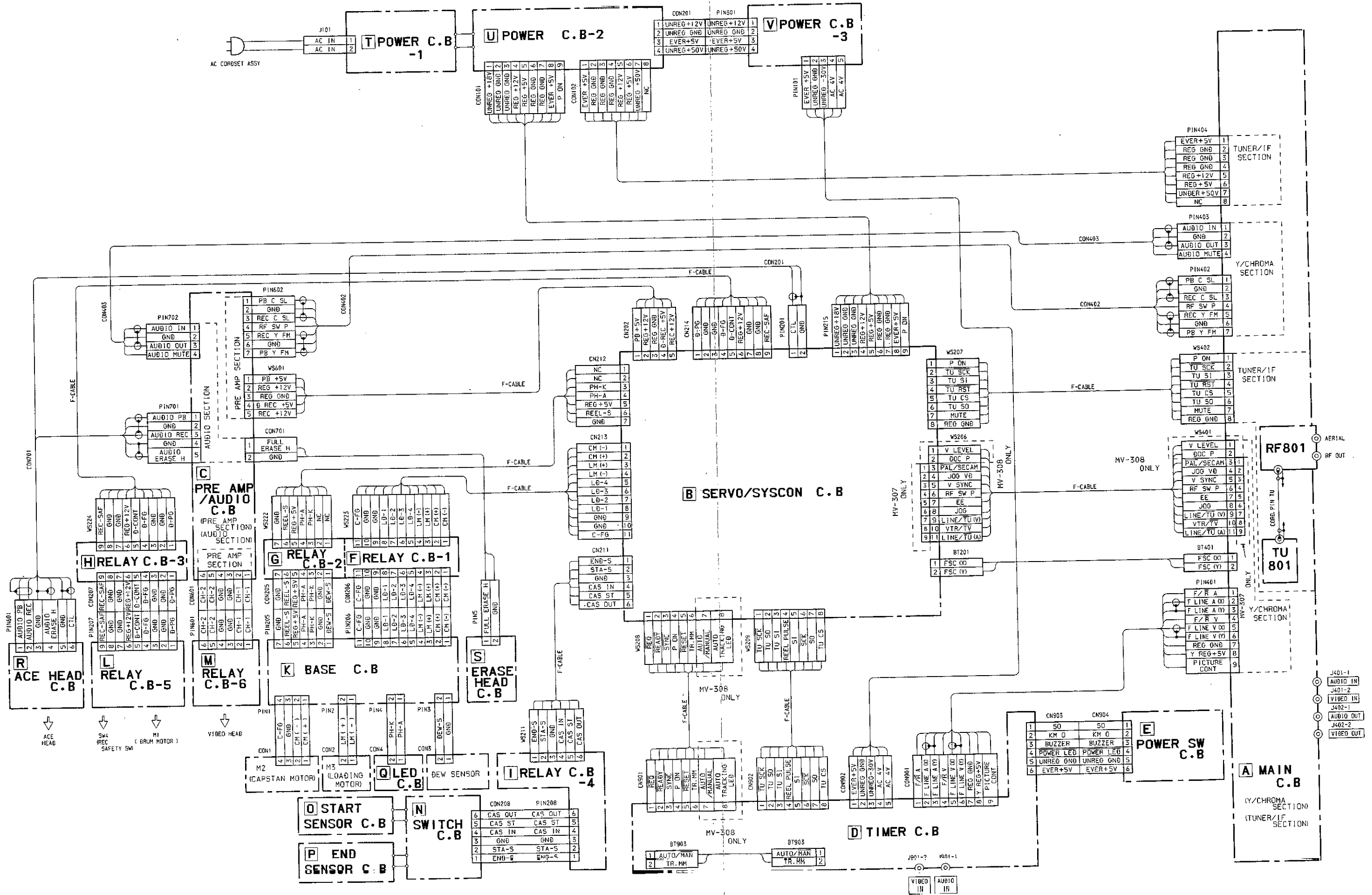











# IC BLOCK DIAGRAM

IC,MSM16811

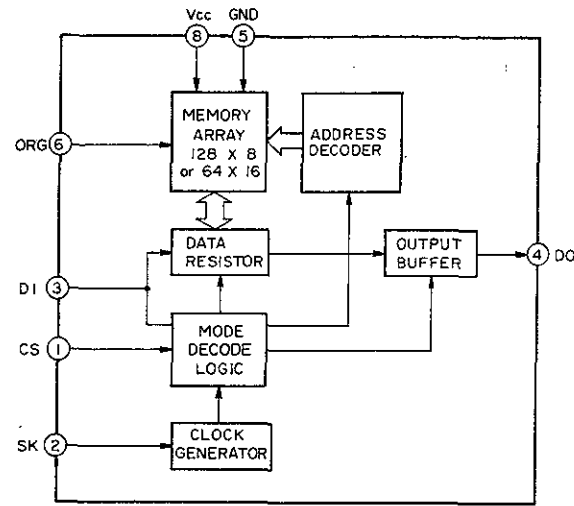

IC,LVA522S

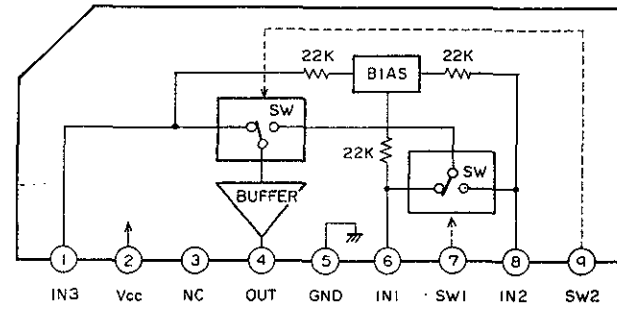

CONTROL INPUT TRUTH TABLE

SW1	SW2	OUT
L	L	IN1
H	L	IN2
L	H	IN3

IC,LC8992

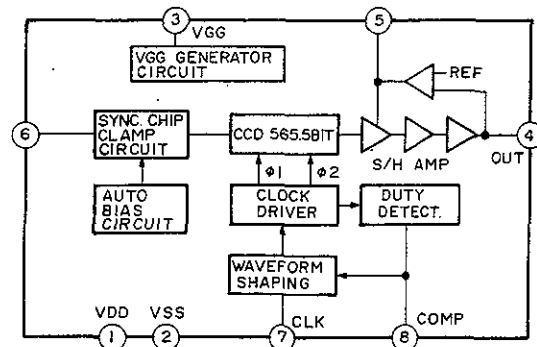

IC,SBX1610

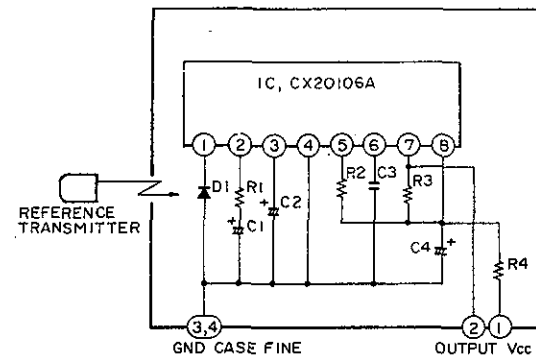

IC,LA7910

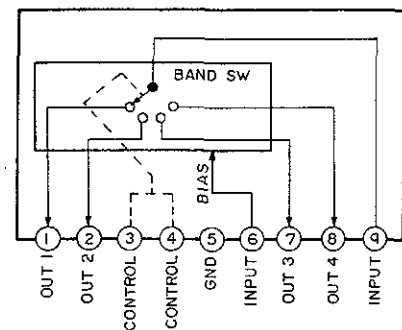

IC,PQ09R05

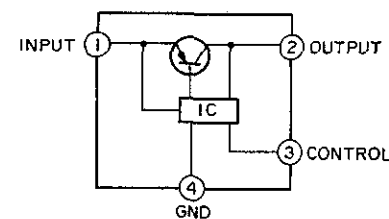

# SYSTEM SWITCH MODE

※When SYSTEM CONTROL IC has run away SYSTEM CONTROL IC will not accept any mode.

STRUCTURE OF SWITCHES

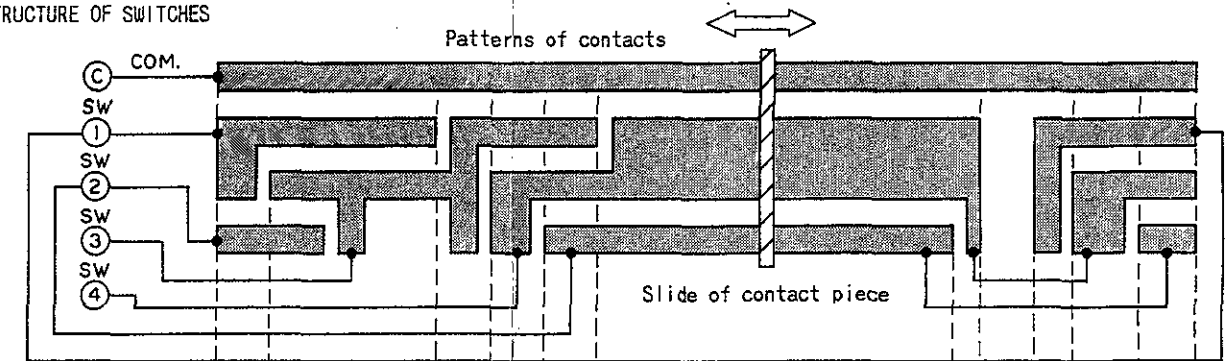

SWITCH STATE DIAGRAM

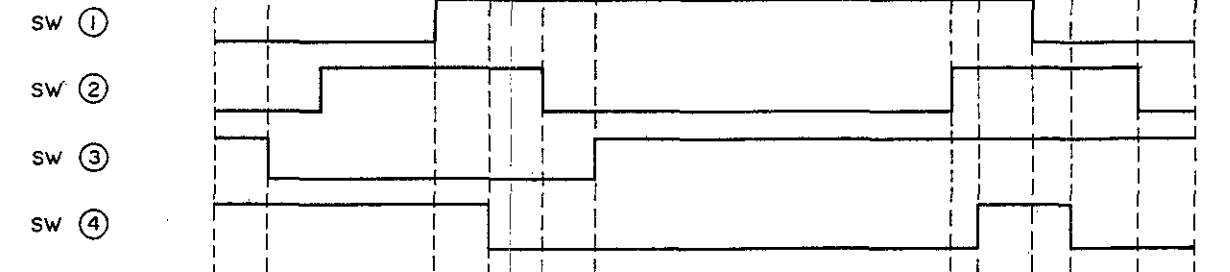

OPERATION POSITIONS

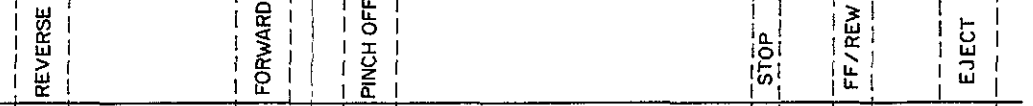

SHIFT OPERATION

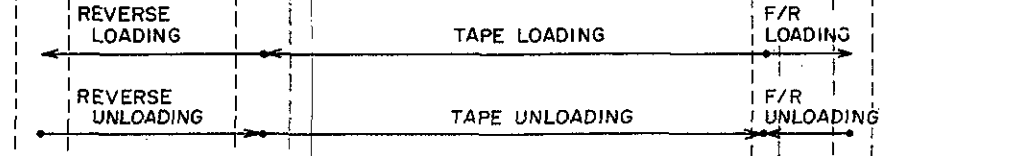

SWITCH				Position
SW1	SW2	SW3	SW4	
0	0	1	0	Front loading, Eject
0	1	1	0	Intermediate
0	1	1	1	F.F., REW
1	1	1	1	Intermediate
1	1	1	0	Stop
1	0	1	0	Tape loading
1	0	0	0	Gear change
1	1	0	0	Intermediate
1	1	0	1	Play (Pause)
0	1	0	1	Intermediate
0	0	0	1	Intermediate
0	0	1	1	Reset

**SCHEMATIC DIAGRAM-3(TUNER)**

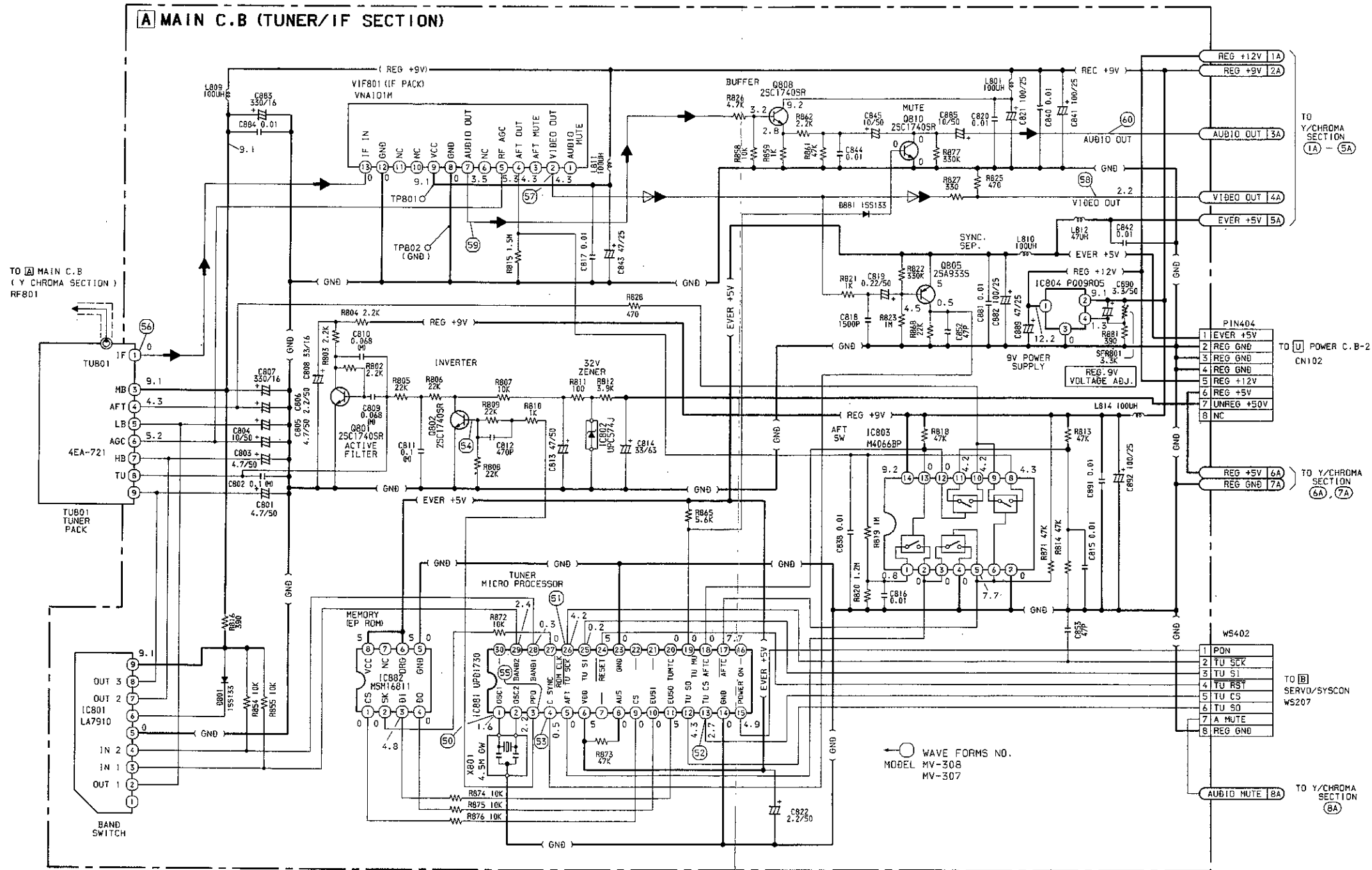

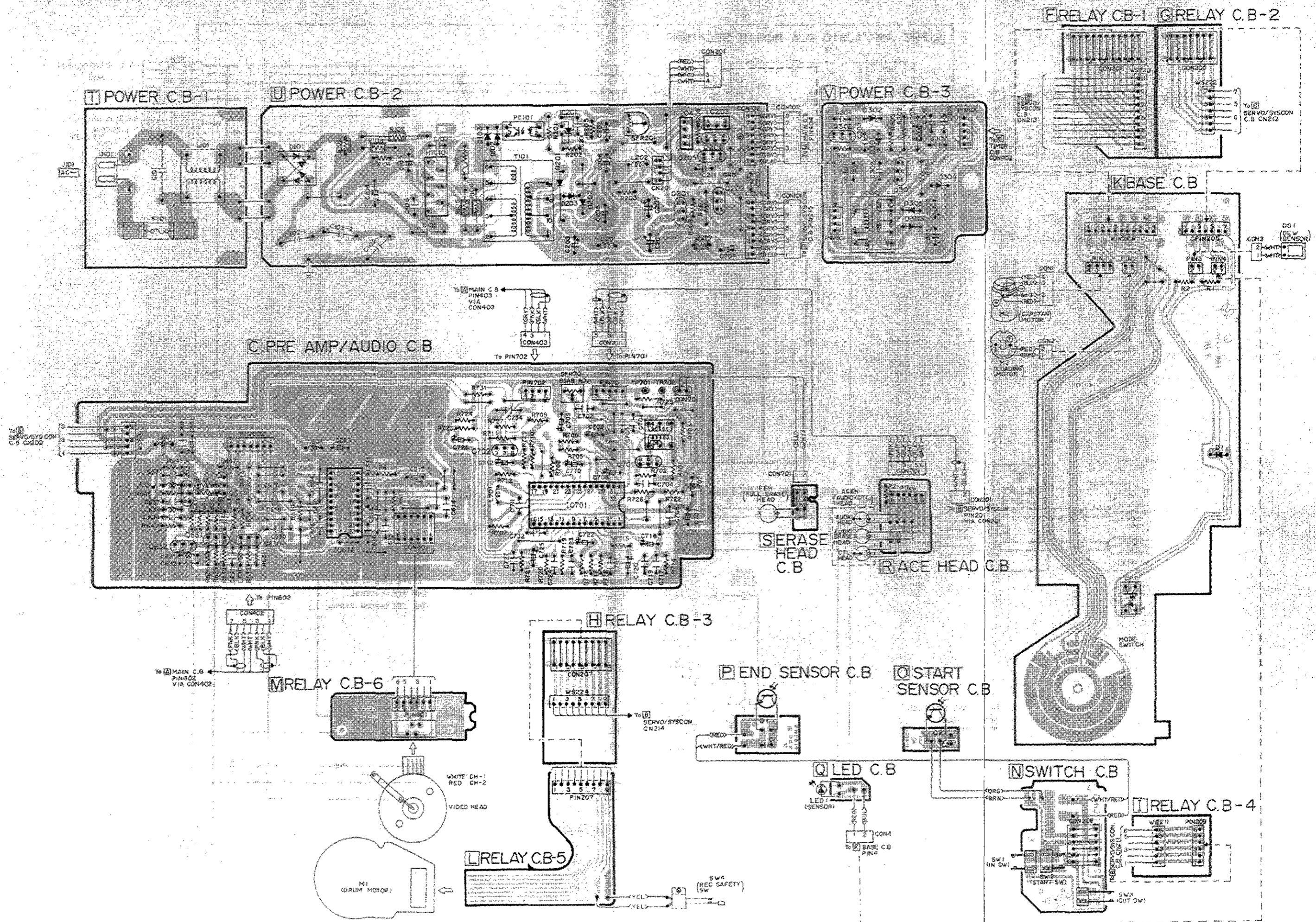

SCHEMATIC DIAGRAM-4(PRE AMP./AUDIO/POWER UNIT)

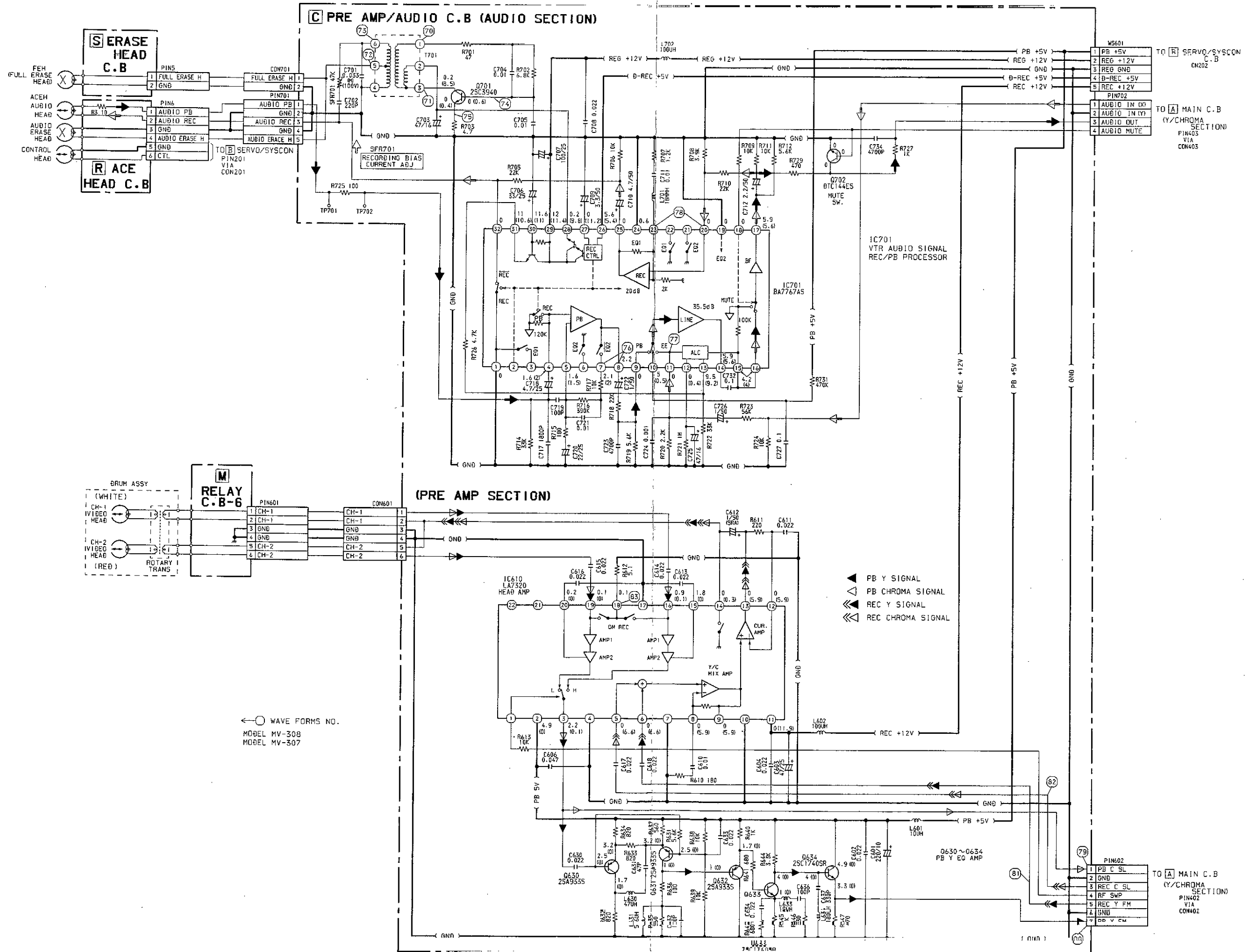

REF NO	DESCRIPTION
HIC101	MA2830F4005
IC201	AN1431T-TZ OR $\mu$ PC1093J-T OR HA17431P
IC203	AN78L05A OR $\mu$ PC78L05JF
IC204	AN78M05RA
Q201	2SB733K3-T
Q202, 205, 206	UN4211-TA OR AA1A4M-T
Q301	2SC4148 OR 2SC2516
Q302	2SC2274AA-NP OR 2SC2002-T
PC101	ON 3171R
$\theta$ 101	SIWBA60
$\theta$ 102, 301	1SS202 (1)-T1 OR MA165-TA5 OR 1SS270A-T $\theta$
$\theta$ 103	R06.2F-B2-T7 OR HZ6.2CP-TK
$\theta$ 201, 202	S3LA20-04P15
$\theta$ 203	$\theta$ 1NL-20-4070
$\theta$ 205	R024F-B2-T7 OR HZ24BP-TK
$\theta$ 302	R02.7ESB2-T1
$\theta$ 303, 305	$\theta$ 1NL20-4070 OR ERA91-02-V5
$\theta$ 304	R047EB-T1

WAVE FORMS NO  
MODEL MV-306  
MODEL MV-307

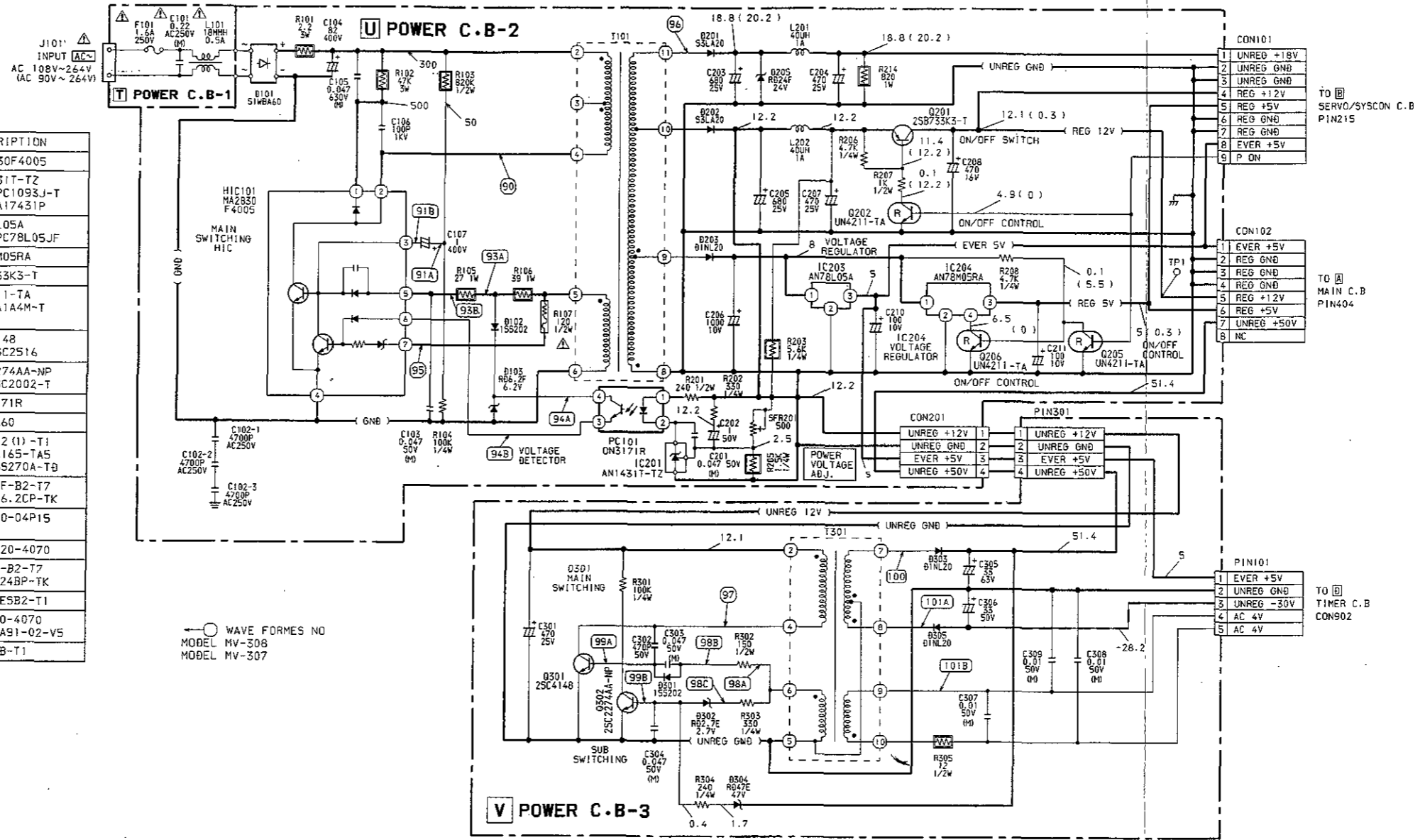



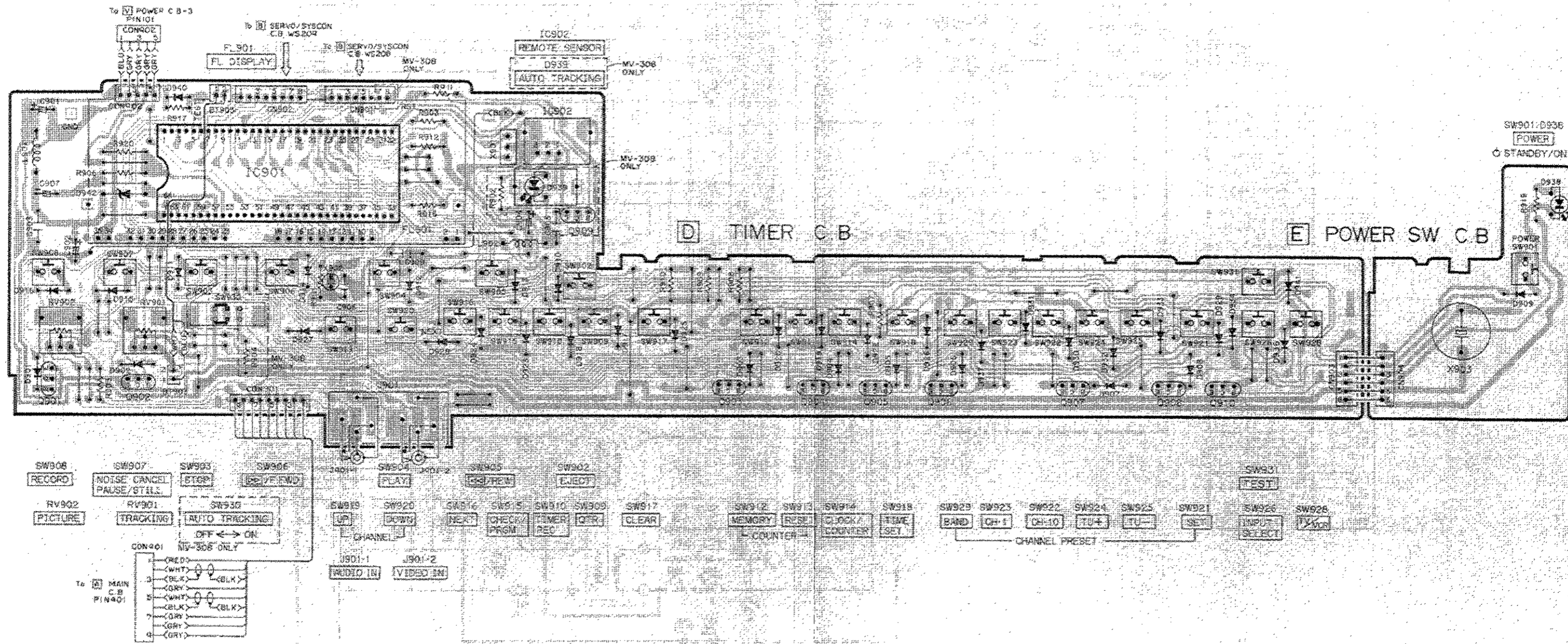



WAVE FORM

VIDEO WAVE FORM

IC411 pin (21) (PB)  
20 $\mu$ s/div.  
500mV/div.  
LINE OUT 75 $\Omega$  TERMINATE

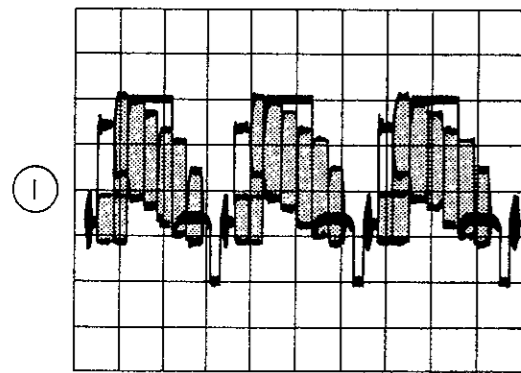

IC461 pin (18) (PB)  
100ns/div.  
500mV/div.

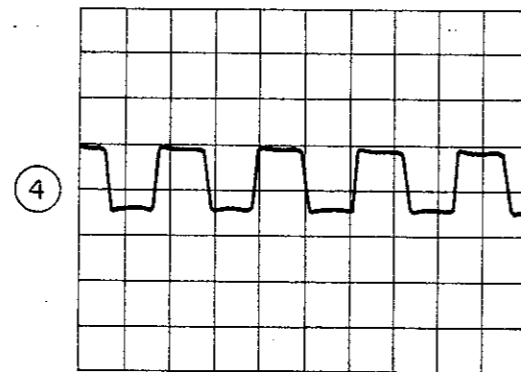

IC461 pin (3) (PB)  
20 $\mu$ s/div.  
50mV/div.

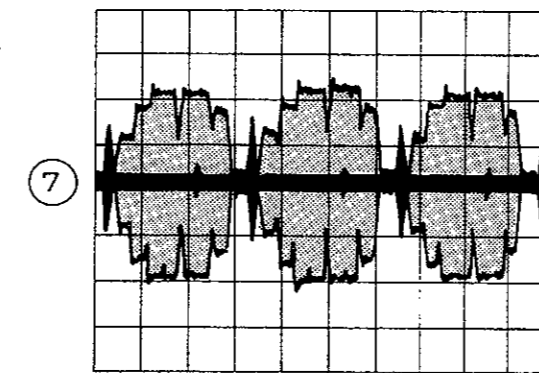

PIN402 pin (1) (PB)  
5ms/div.  
100mV/div.

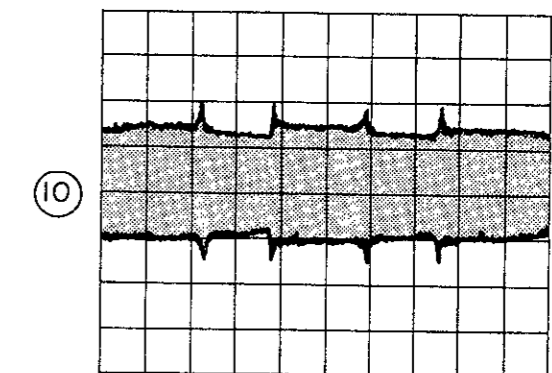

LINE OUT  
20 $\mu$ s/div.  
500mV/div.  
LINE OUT 75 $\Omega$  TERMINATE

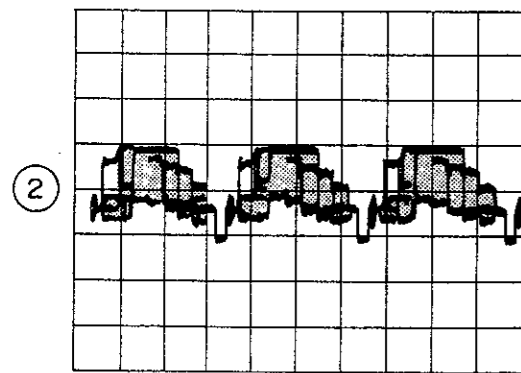

IC461 pin (19) (PB)  
100ns/div.  
500mV/div.

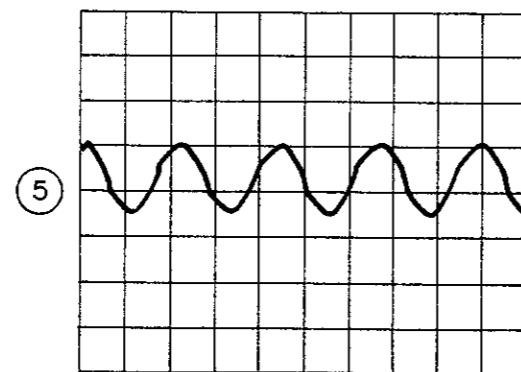

IC461 pin (24) (PB)  
20 $\mu$ s/div.  
50mV/div.

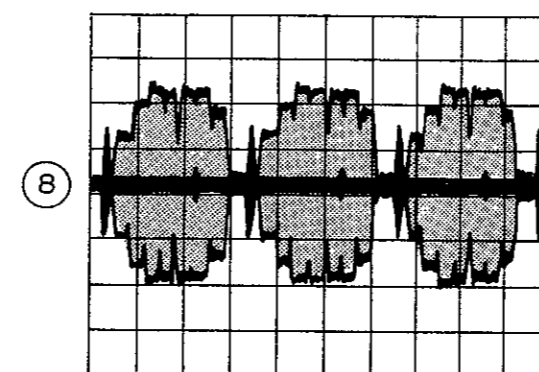

IC461 pin (7) (PB)  
20 $\mu$ s/div.  
100mV/div.

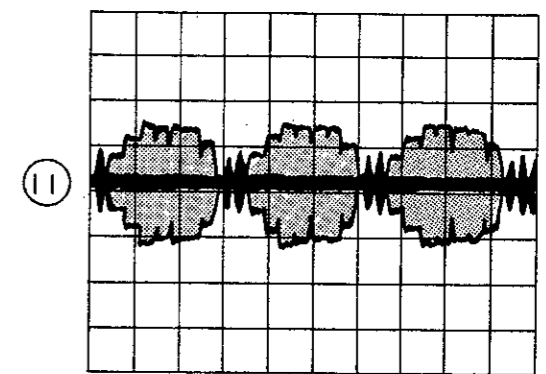

IC411 pin (19) (PB)  
20 $\mu$ s/div.  
100mV/div.

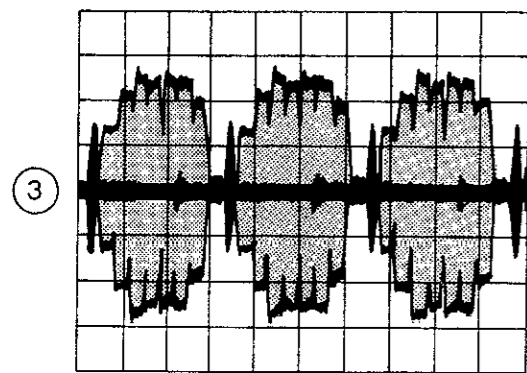

IC461 pin (5) (PB)  
20 $\mu$ s/div.  
500mV/div.

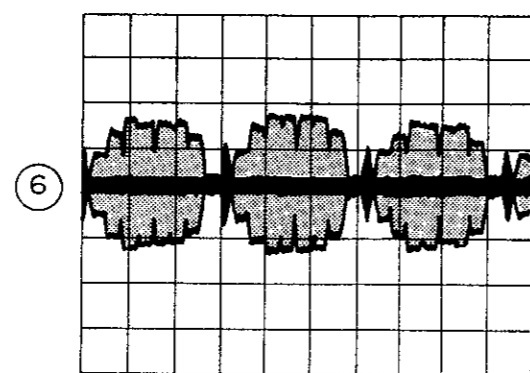

IC411 pin (9) (PB)  
20 $\mu$ s/div.  
100mV/div.

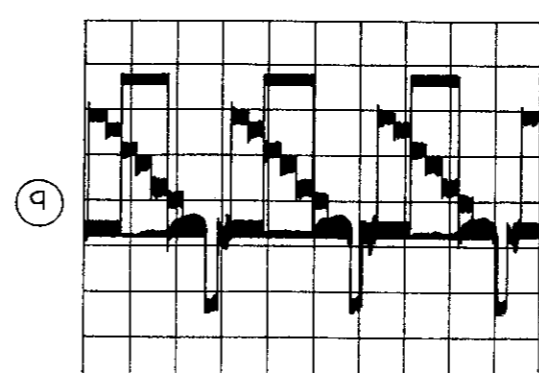

PIN402 pin (7) (PB)  
5ms/div.  
200mV/div.

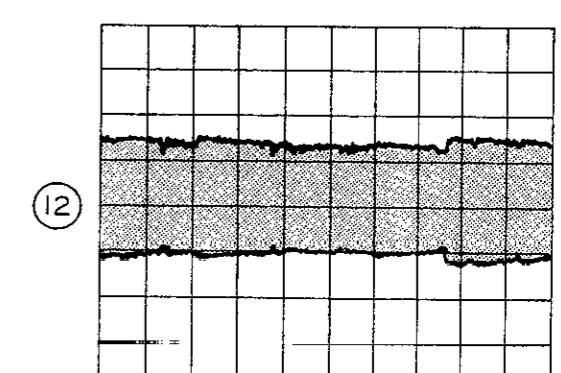



IC411 pin ⑦ (PB)  
20 $\mu$ s/div.  
500mV/div.

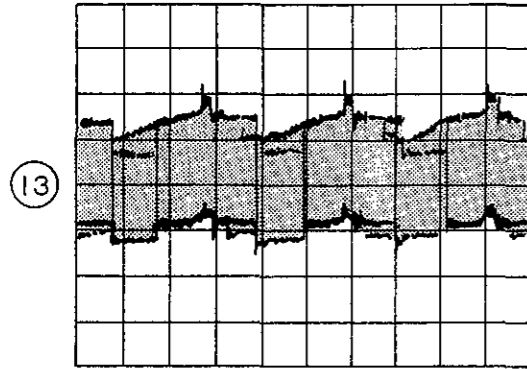

LINE OUT (EE)  
20 $\mu$ s/div.  
500mV/div.

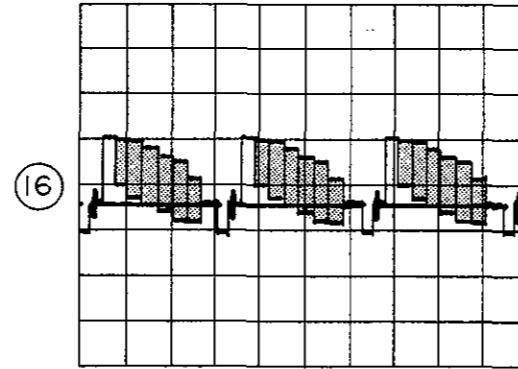

IC461 pin ⑪  
100ns/div.  
100mV/div.

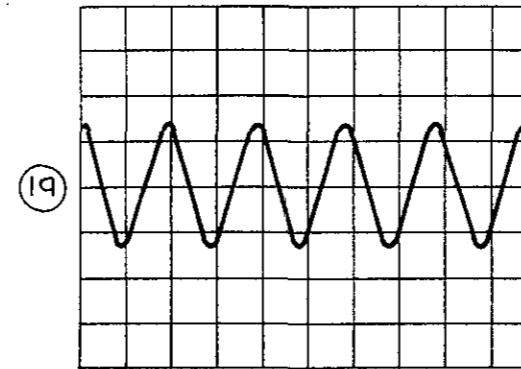

IC461 pin ⑱ (EE)  
50mV/div.  
100ns/div.

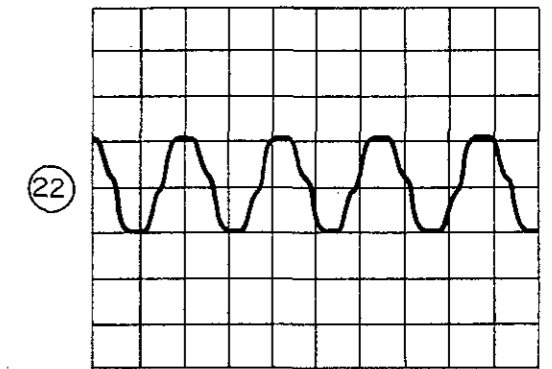

FIL411 OUT (PB)  
20 $\mu$ s/div.  
100mV/div.

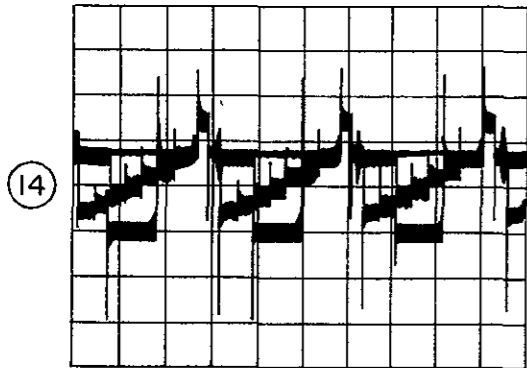

IC461 pin ⑲ (EE)  
100ns/div.  
500mV/div.

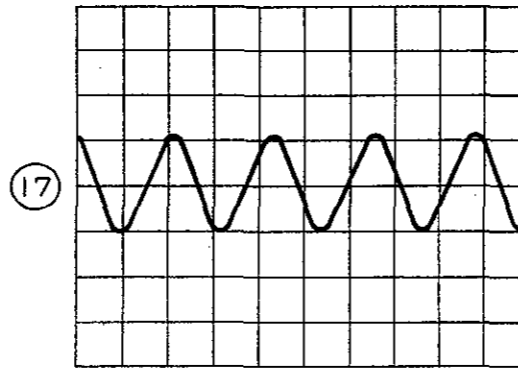

IC461 pin ⑨ (EE)  
200mV/div.  
20 $\mu$ s/div.

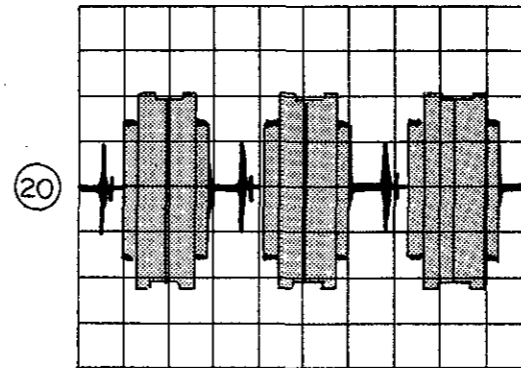

PIN402 pin ⑤ (EE)  
100mV/div.  
20 $\mu$ s/div.

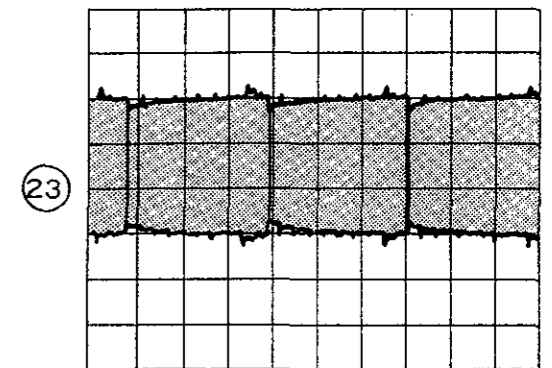

IC411 pin ⑳ (EE)  
20ns/div.  
500mV/div.

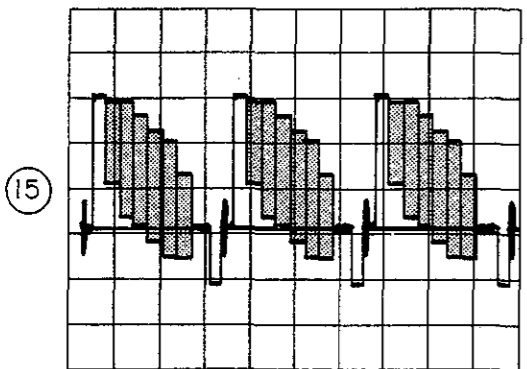

IC461 pin ⑬  
100ns/div.  
100mV/div.

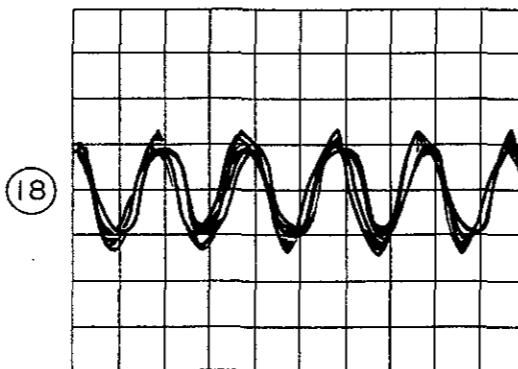

PIN402 pin ③ (EE)  
50mV/div.  
20 $\mu$ s/div.

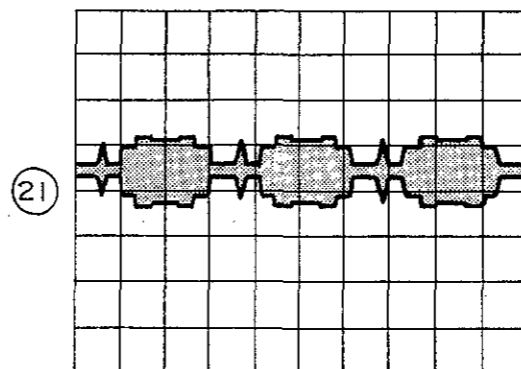

IC461 pin ⑤ (EE)  
100mV/div.  
20 $\mu$ s/div.

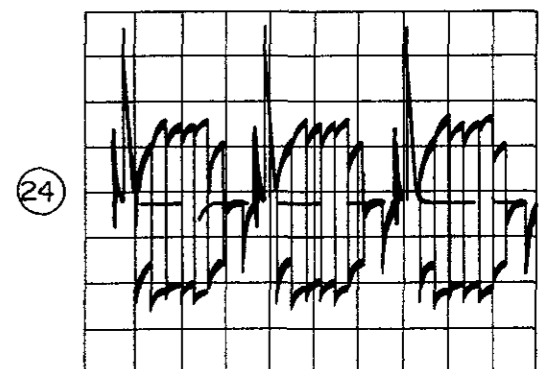

IC461 pin (3) (EF)  
50mV/div.  
20μs/div.

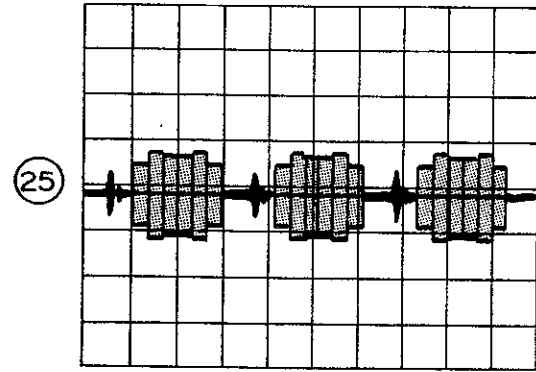

IC411 pin (6) (EE)  
20μs/div.  
100mV/div.

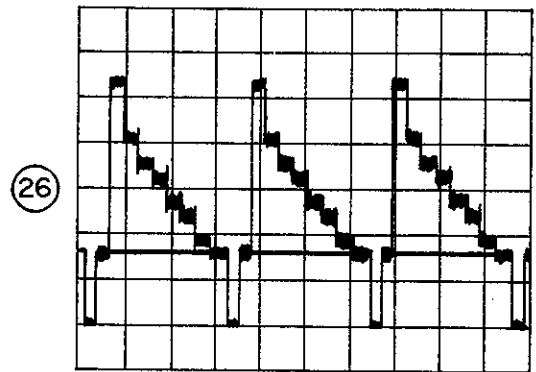

IC411 pin (2) (EE)  
20μs/div.  
200mV/div.

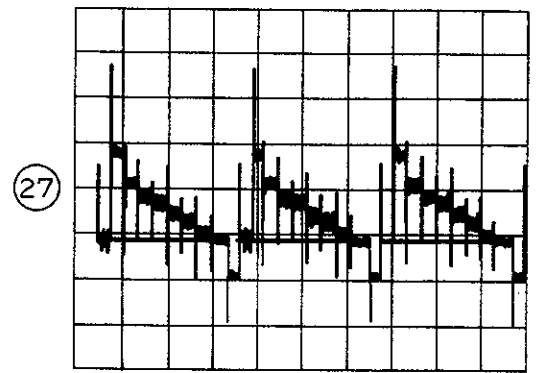

IC411 pin (30) (EE)  
200ns/div.  
500mV/div.

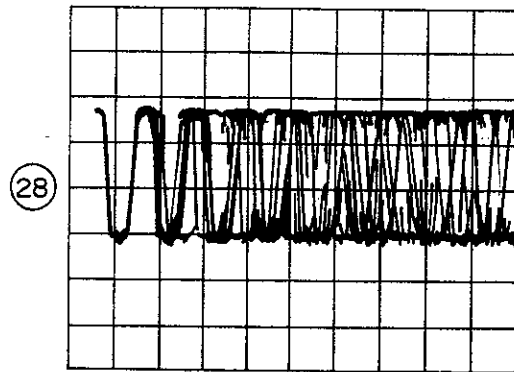

LINE IN (EE)  
20μs/div.  
200mV/div.

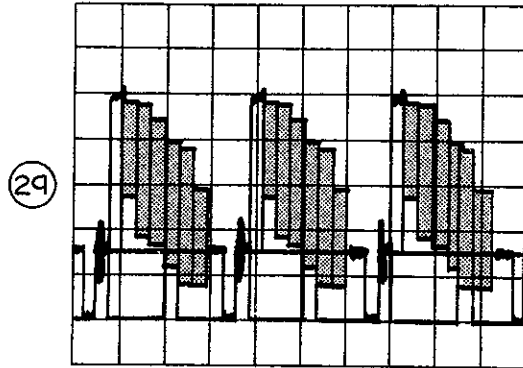

IC411 pin (24) (EE)  
20μs/div.  
200mV/div.

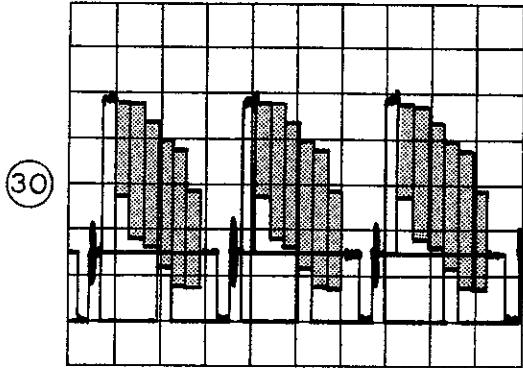

IC411 pin (7) (EE)  
20μs/div.  
200mV/div.

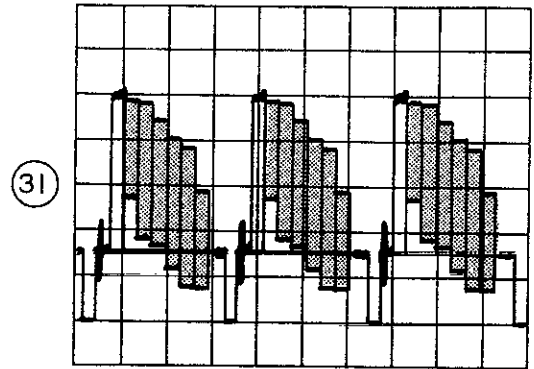

### SERVO WAVE FORM

- DRUM PG AND FG  
Upper : DRUM PG AC 0.1V/div.  
(IC203 pin (16) )  
Lower : DRUM FG AC 50mV/div.  
(IC203 pin (17) )  
Time 5ms/div.

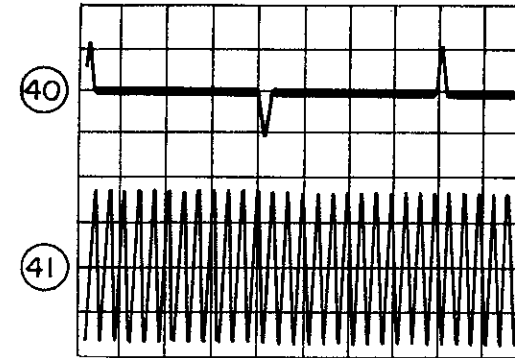

- DRUM PG AND FG  
Enlargement of 1  
The PG pulse (upper) is generated (either positive or negative) when the FG pulse (lower) is a negative half wave.

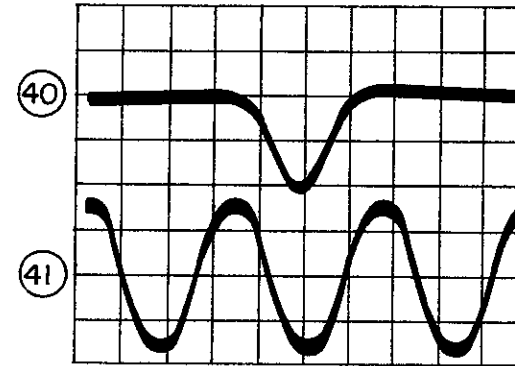

- CAPSTAN FG (IC203 pin (18) )  
AC 0.1V/div.  
Time 1ms/div.

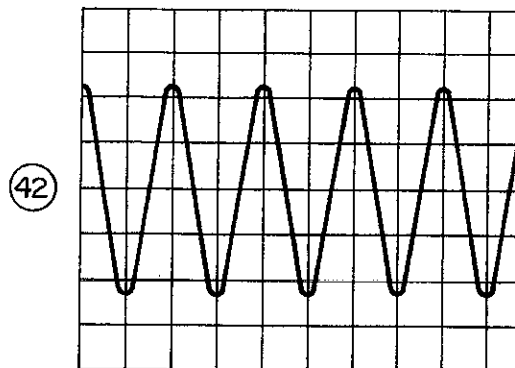

- RF SW PULSE AND CTL (PB MODE)  
RF SW PULSE DC 1V/div. (IC203 pin (10) )  
CTL AC 0.5V/div. (IC203 pin (22) )  
Time 5ms/div.  
The CTL pulse (negative) is  $2.3 \pm 0.3$ ms from the leading edge of the RF SW pulse.

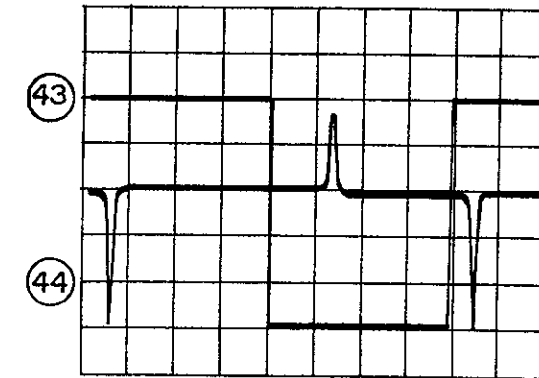

- RF SW PULSE AND CTL (REC MODE)  
Upper : RF SW PULSE DC 2V/div.  
(IC203 pin (10) )  
Lower : CTL AC 2V/div.  
(IC203 pin (22) )  
Time 5ms/div.

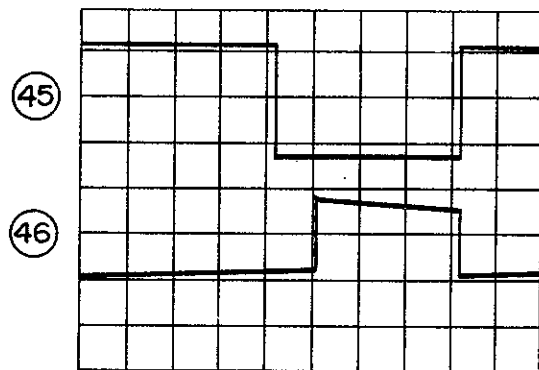

6. RF SW PULSE AND VIDEO OUT  
 RF SW PULSE DC 1V/div. (IC203 pin ⑩)  
 Video out (OPEN) AC 0.5V/div.  
 Time 0.1ms/div.  
 The RF SW pulse rises or falls 5~8H (320~512 $\mu$ s) before the VD (vertical sync) signal in the video signal.

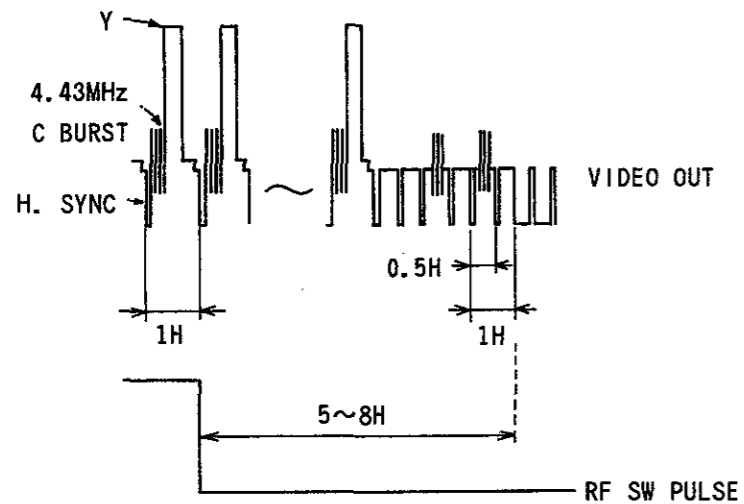
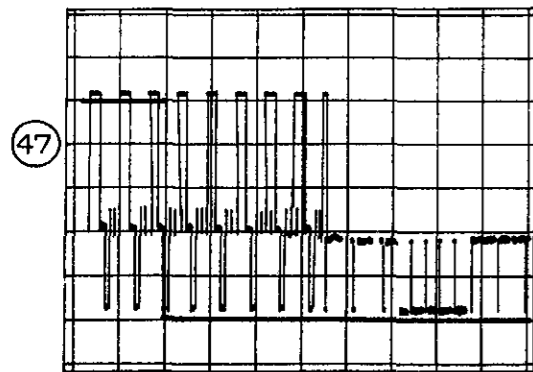

### TUNER WAVE FORM

IC881 pin ①  
 Oscillated by the microprocessor  
 1V/div.  
 200ns/div.

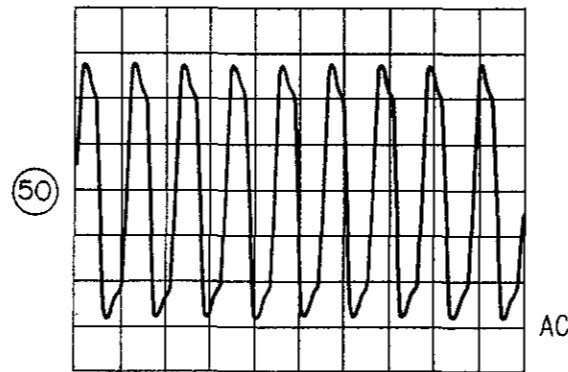

IC881 pin ④  
 H. sync  
 2V/div.  
 20 $\mu$ s/div.

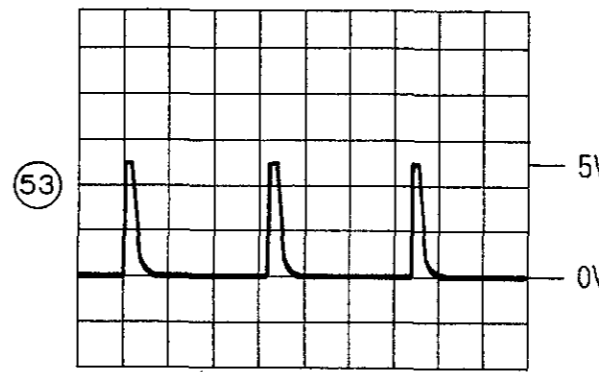

TU801 pin ①  
 IF signal  
 P: Color bar signal  
 50ms/div.  
 20 $\mu$ s/div.

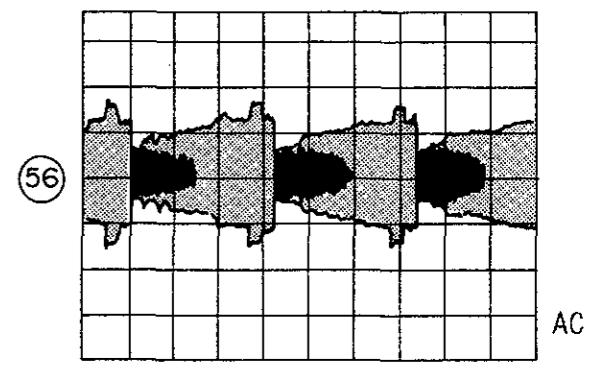

IC881 pin ②⑥  
 Clock of microprocessor  
 2V/div.  
 20ms/div.

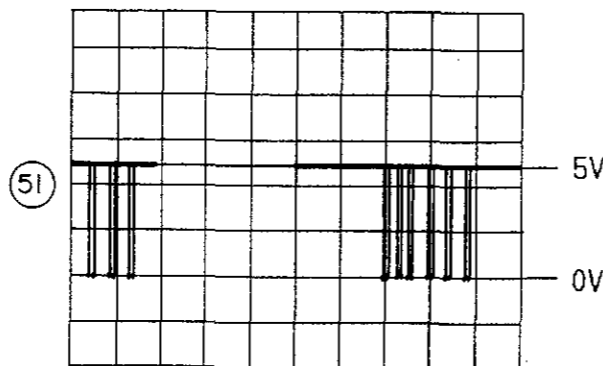

Q802 base  
 1V/div.  
 50 $\mu$ s/div.

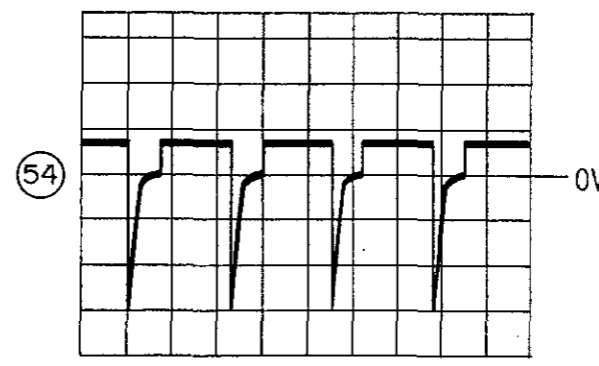

VIF801 pin ②  
 500mV/div.  
 20 $\mu$ s/div.

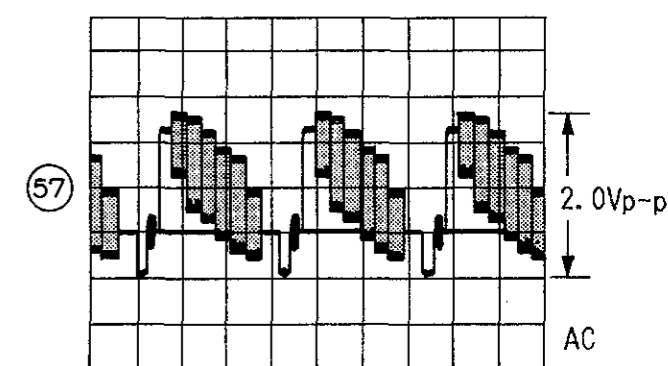

IC881 pin ⑬  
 Microprocessor chip select  
 2V/div.  
 20ms/div.

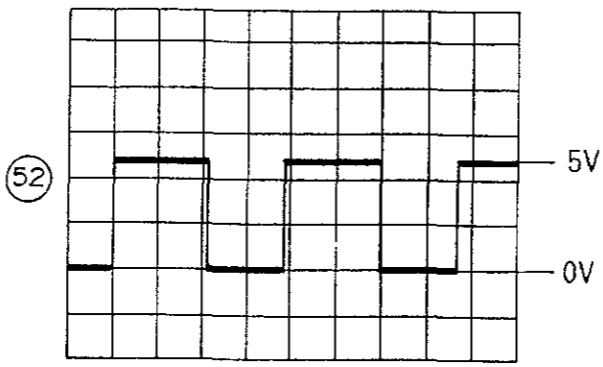

IC881 pin ③  
 Pulse for generating a tuning voltage  
 The pulse width varies for different channels.  
 2V/div.  
 50 $\mu$ s/div.

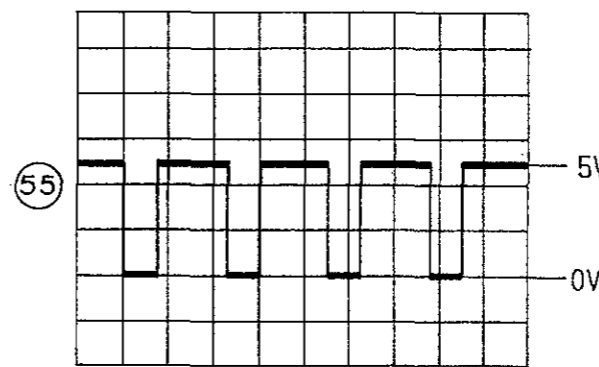

TP805  
 TU VIDEO OUT 75 $\Omega$  TERMINATE  
 500mV/div.  
 20 $\mu$ s/div.



AUDIO WAVE FORM

VIF801 pin ⑦  
 TU AUDIO OUT  
 When modulated  
 at 400Hz and 50kHz  
 500mV/div.  
 1ms/div.

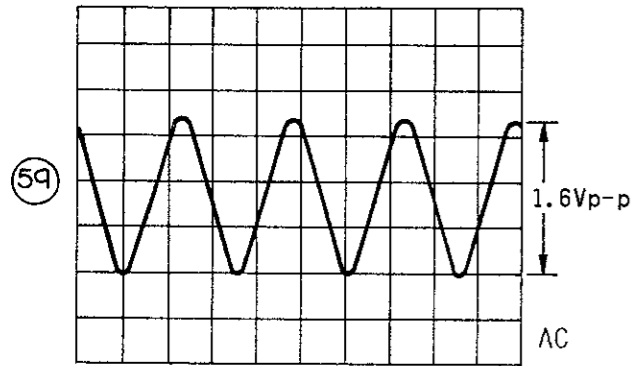

TP804  
 TU AUDIO OUT  
 When modulated  
 at 400Hz and 50kHz  
 200mV/div.  
 1ms/div.

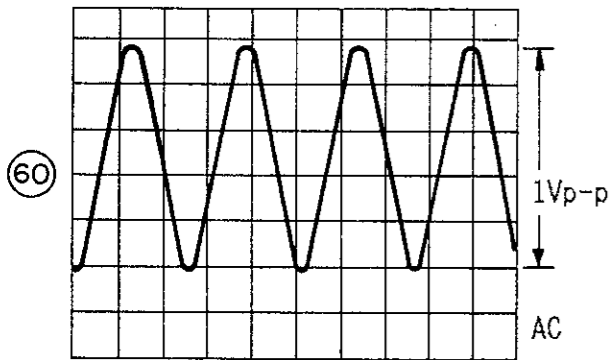

T701 pin ①  
 5V/div.  
 2μs/div.

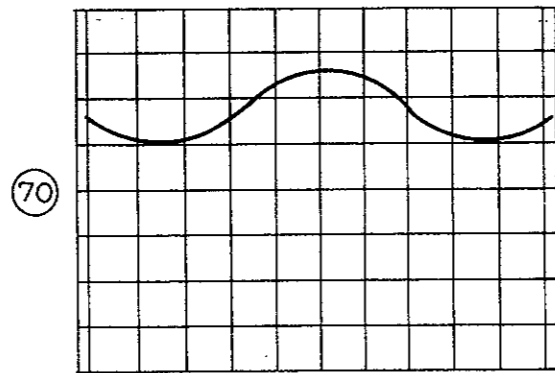

T701 pin ③  
 10V/div.  
 2μs/div.

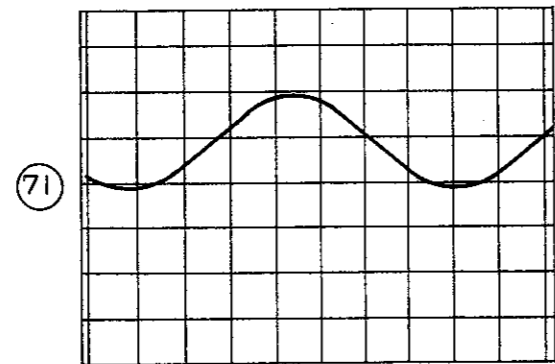

T701 pin ⑤  
 10V/div.  
 2μs/div.

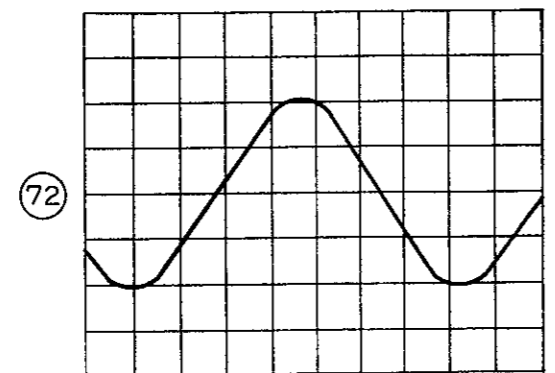

T701 pin ⑥  
 20V/div.  
 2μs/div.

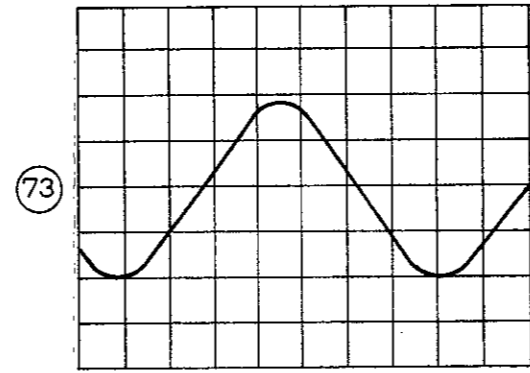

Q701 base  
 1V/div.  
 5μs/div.

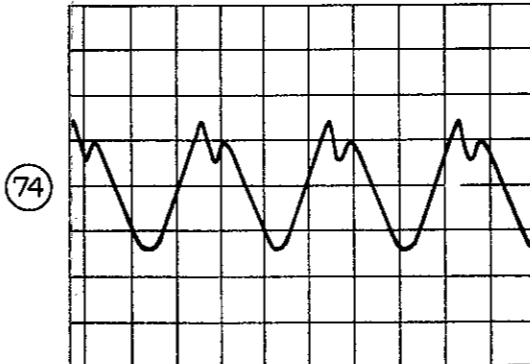

Q701 emitter  
 500mV/div.  
 5μs/div.

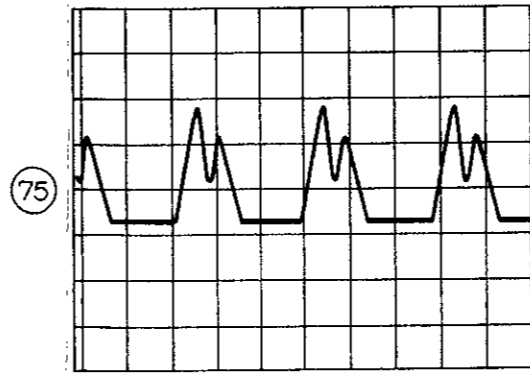

IC701 pins ⑦ and ⑧  
 20mV/div.  
 200μs/div.

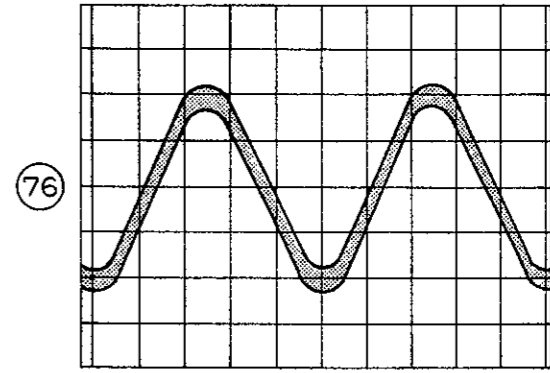

- The wave form shown in the photo on the left is at pin ① of IC701.
- IC701 pins ⑭ to ⑰ are 900mVp-p.
- The specification of the EE level is -8.5 ±1dBs when a 1kHz-10dBs signal is input.  
 20mV/div.  
 500μs/div.

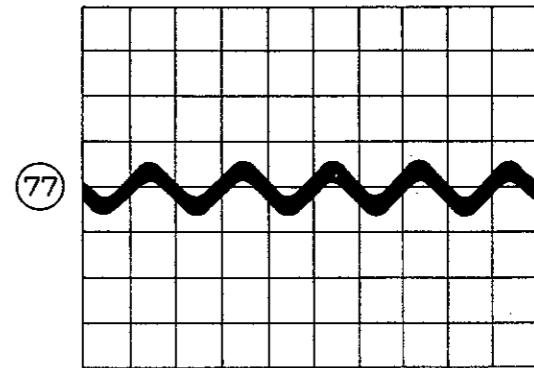

- The wave form shown in the photo on the left is at pins ⑳ and ㉓ of IC701.
- IC701 pin ㉓ is 1.53Vp-p.  
50mV/div.  
200μs/div.

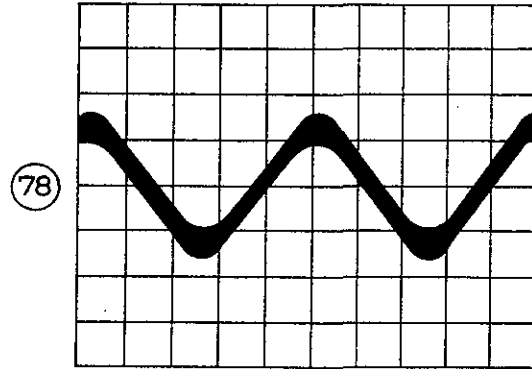

- PIN602 pin ① (PB)  
5ms/div.  
100mV/div.

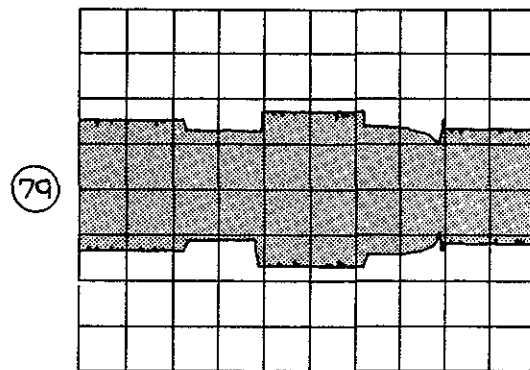

- PIN602 pin ⑦ (PB)  
5ms/div.  
200mV/div.

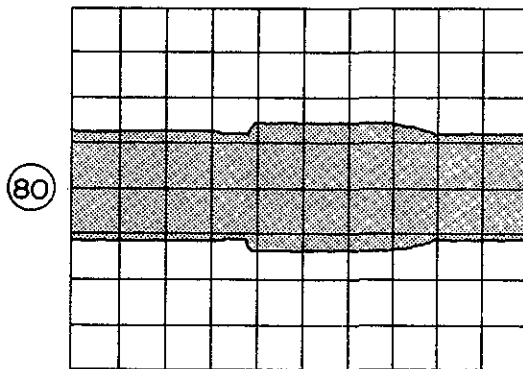

- PIN602 pin ⑤ (REC)  
20μs/div.  
100mV/div.

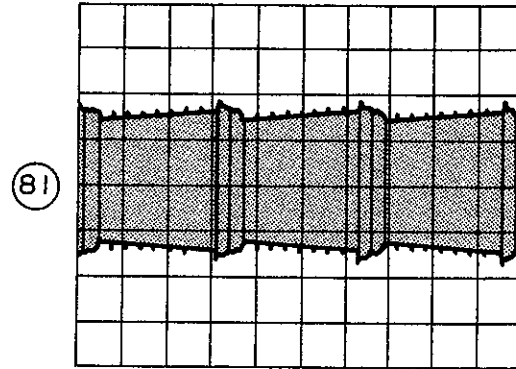

- PIN602 pin ③ (REC)  
20μs/div.  
20mV/div.

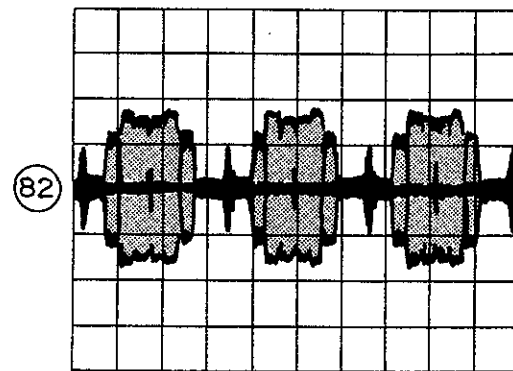

- IC610 pin ⑱ (REC)  
20μs/div.  
50mV/div.

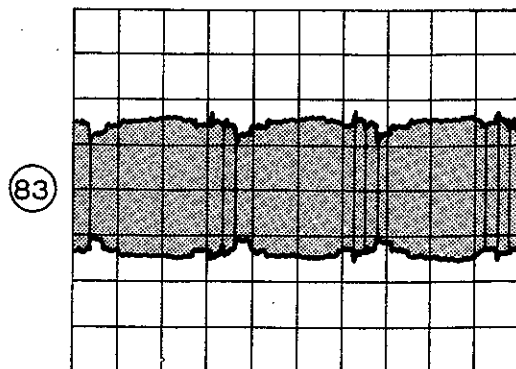

## POWER UNIT WAVE FORM

- HIC101 pin ② WAVE FORM  
(T101 pin ④ )  
500Vp-p  
200μs/div.

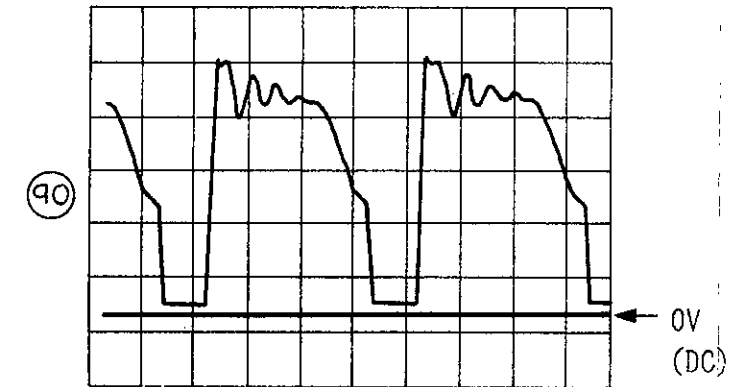

- C107 ⊕ SIDE ( ㉑ -A)  
1V/div.  
2μs/div.
- C107 ⊖ SIDE (HIC101 pin ③ )( ㉑ -B)  
1V/div.  
2μs/div.

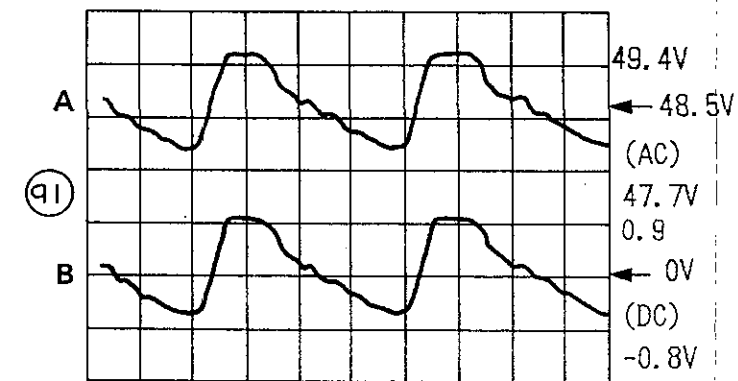

- T101 pin ⑤  
5V/div.  
2μs/div.

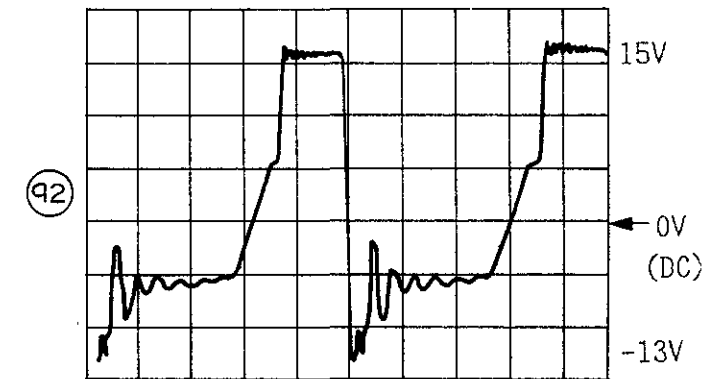

- D102 ANODE SIDE ( ㉓ -A)  
5V/div.  
2μs/div.
- HIC101 pin ⑤ ( ㉓ -B)  
5V/div.  
2μs/div.



- ※ • When checking waveforms (90) - (95), connect the negative (-) terminal of C104 to ground (GND on primary side).
- When checking waveforms (96) and (101), connect pin 2 of CON101 to ground (GND on secondary side).
- Waveforms should be measured in the PB mode and with AC 220V power input.

- D102 CATHOD SIDE ( 94 -A)  
2V/div.  
2μs/div.
- HIC101 pin 6 ( 94 -B)  
2V/div.  
2μs/div.

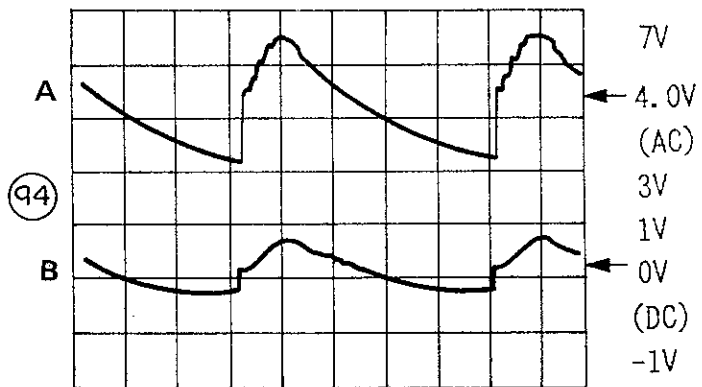

- Q301 COLLECTOR SIDE  
5V/div.  
2μs/div.



- Q301 BASE SIDE ( 99 -A)  
0.5V/div.  
2μs/div.
- Q302 BASE SIDE ( 99 -B)  
0.5V/div.  
2μs/div.

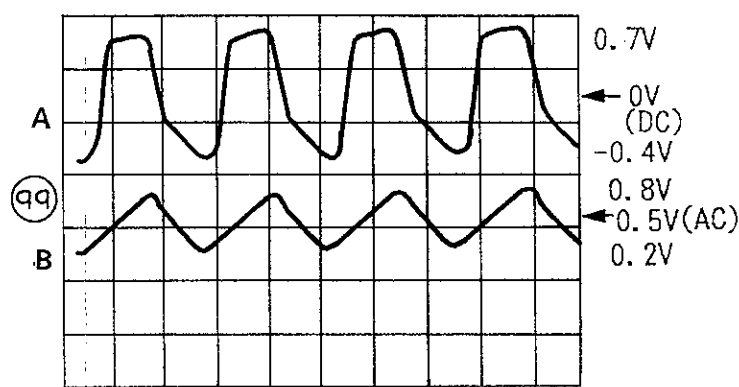

- T301 pin 8 ( 101 -A)  
20V/div.  
2μs/div.
- T301 pin 9 ( 101 -B)  
2V/div.  
2μs/div.

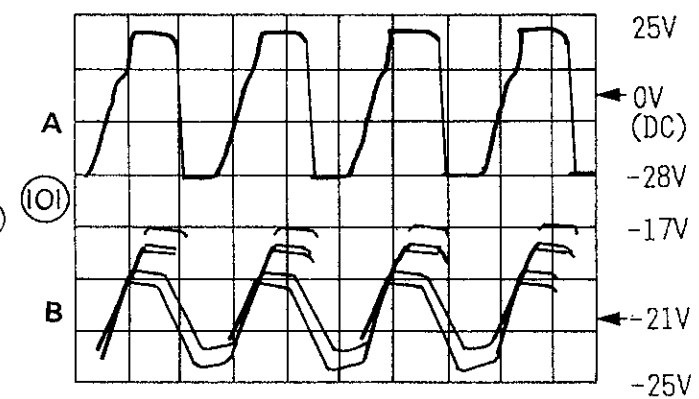

- HIC101 pin 7  
5V/div.  
2μs/div.

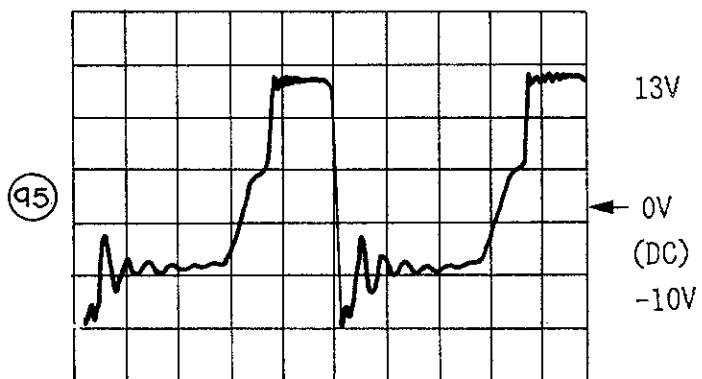

- T301 pin 6 ( 98 -A)  
5V/div.  
2μs/div.
- D302 CATHOD SIDE ( 98 -B)  
5V/div.  
2μs/div.
- D301 ANODE SIDE ( 98 -C)  
2V/div.  
2μs/div.

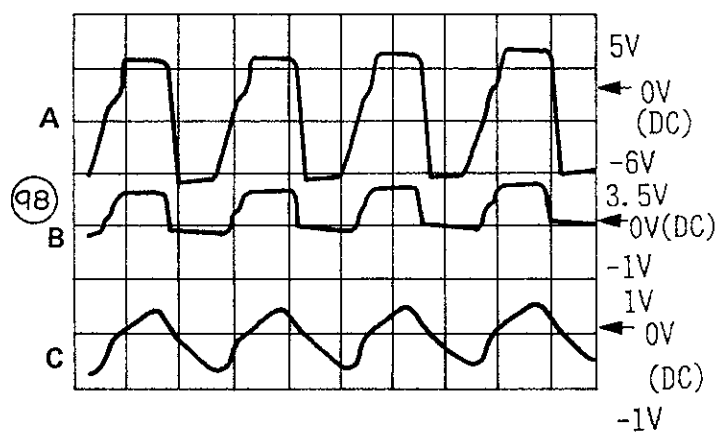

- D303 ANODE SIDE  
20V/div.  
2μs/div.

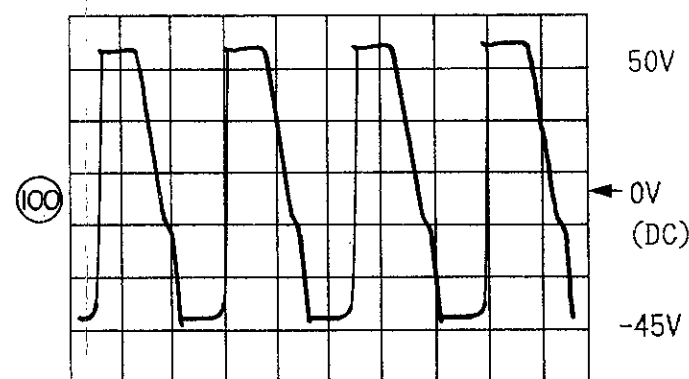

### TIMER WAVE FORM

- Q901 DTC144E Base  
2ms/div.  
2V/div.

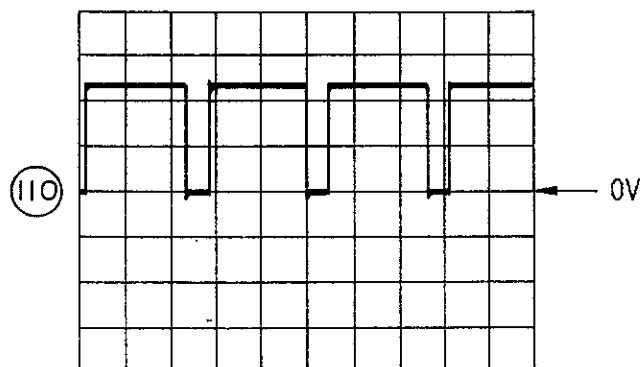

- T101 pin 11  
10V/div.  
2μs/div.

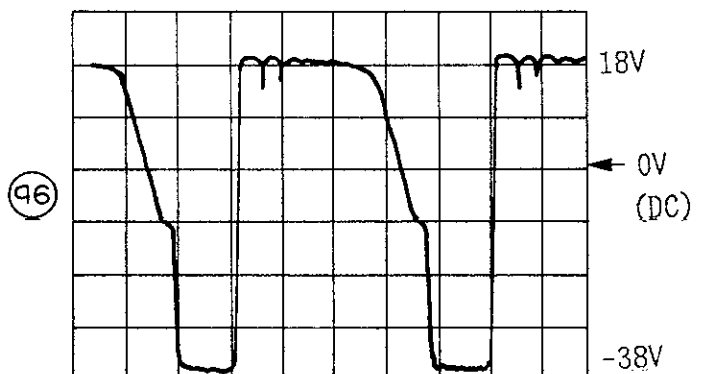

Anode voltage  
IC901 pin (58) : S9  
2ms/div.  
10V/div.

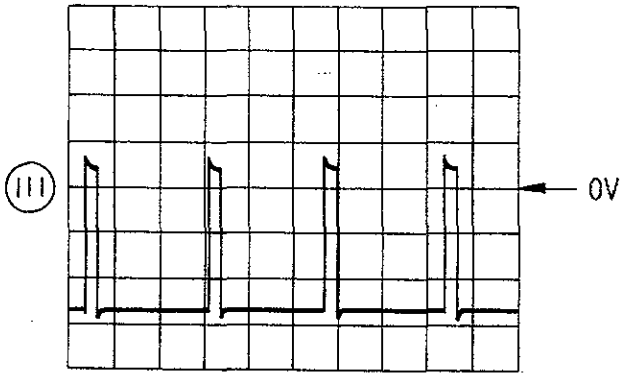

Filament voltage  
CON902 pin (5) : AC 4V  
DC range  
2μs/div.  
10V/div.

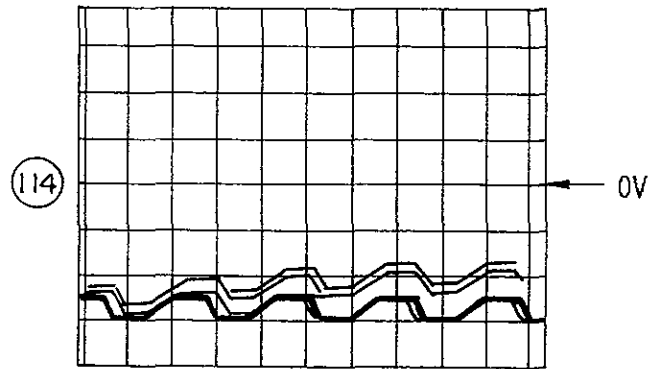

Grid voltage  
IC901 pin (40) : T0  
2ms/div.  
10V/div.

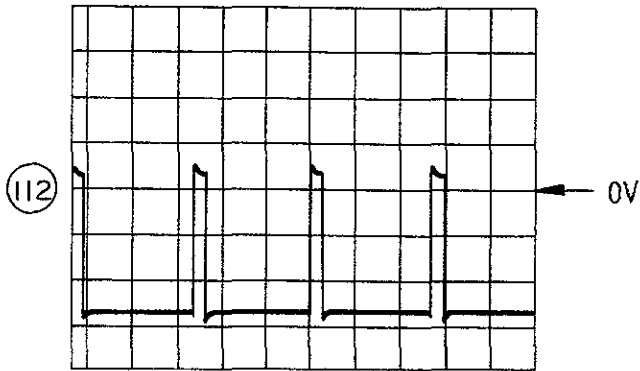

Main clock  
IC901 pin (31) : X  
4.19MHz  
100ns/div.  
2V/div.

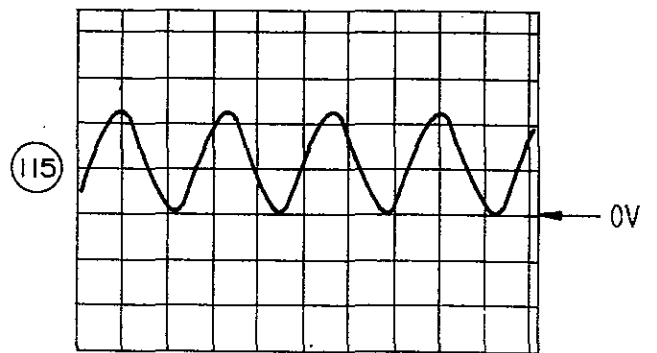

Filament voltage  
CON902 pin (5) : AC 4V  
AC range  
2μs/div.  
5V/div.

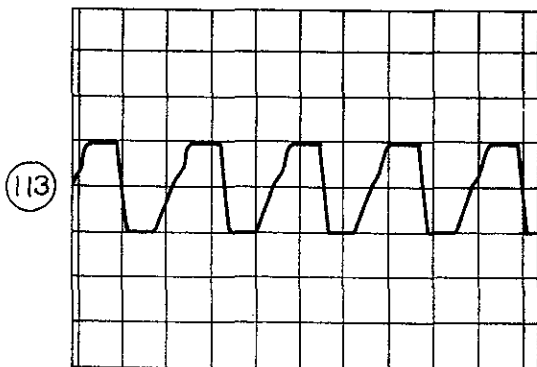

Sub-clock  
IC901 pin (34) : XT  
32.768kHz  
20μs/div.  
2V/div.

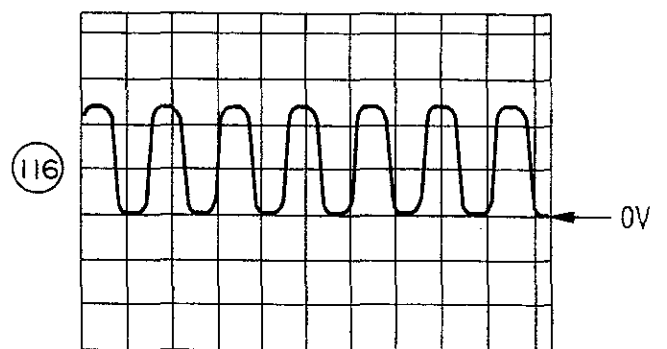

# IC DESCRIPTION

IC, MB88525-205M (IC201)

Pin No.	Pin Name	I/O	Description	Active																
1	TOP-SENSOR (START)	I	Receives the tape top (start) detection signal and A) Prevents the tape running in the reverse direction. B) Shifts the unit to the stop mode if this signal is input when the tape is running in reverse.	H																
2	END-SENSOR	I	Receives the tape end detection signal and A) Prevents the tape running in the forward direction. B) Shifts the unit to the stop mode if this signal is input when the tape is running in forward.	H																
3	RF-SWP	I	Receives drum rotation pulses. When pulses are not input for 2 seconds in a mode where the drum is rotating due to an abnormality in the tape or deck mechanism, the VCR enters the stop mode to protect the tape.	Pulse																
4	REEL-SENSOR	I	Receives a signal from the reel sensor in the deck mechanism. When pulses are not input for 2 seconds in a mode where the reel is rotating due to an abnormality in the tape or deck mechanism, the VCR enters the stop mode to protect the tape.	Pulse																
5	$\overline{\text{CASSETTE}}\text{-OUT}$	I	The CASSETTE OUT switch in the cassette loading mechanism is connected to detect the cassette-out state (eject). Instructs the cassette out operation (unloading) to stop.	L																
6	$\overline{\text{CASSETTE}}\text{-START}$	I	The CASSETTE START switch in the cassette loading mechanism is connected to instruct the cassette-in operation (loading). When the input is detected during the cassette-out operation, the capstan motor is pulse driven.	L																
7	$\overline{\text{CASSETTE}}\text{-IN}$	I	The cassette-in switch in the cassette loading mechanism is connected to detect the cassette-in state.	L																
8	—	—	Unused (pulled up).	—																
9	MODE SW 1	I	These pins detect the position of the tape sledding mechanism.	L																
10	MODE SW 2	I		L																
11	MODE SW 3	I		L																
12	MODE SW 4	I		L																
13 14	LP·EP-H EP-H	I I	Tape speed detection inputs. <table border="1" style="margin-left: auto; margin-right: auto;"> <thead> <tr> <th></th> <th>NTSC/PAL</th> <th>LP·EP-H</th> <th>EP-H</th> </tr> </thead> <tbody> <tr> <td>SP</td> <td>2H/3H</td> <td>L</td> <td>L</td> </tr> <tr> <td>LP</td> <td>4H/3H</td> <td>H</td> <td>L</td> </tr> <tr> <td>EP</td> <td>6H/6H</td> <td>H</td> <td>H</td> </tr> </tbody> </table>		NTSC/PAL	LP·EP-H	EP-H	SP	2H/3H	L	L	LP	4H/3H	H	L	EP	6H/6H	H	H	H H
	NTSC/PAL	LP·EP-H	EP-H																	
SP	2H/3H	L	L																	
LP	4H/3H	H	L																	
EP	6H/6H	H	H																	
15 16	MESECAM/PAL NTSC/PAL	I I	Video system discrimination inputs. <table border="1" style="margin-left: auto; margin-right: auto;"> <thead> <tr> <th>NTSC/PAL</th> <th>MESECAM/PAL</th> <th>MODE</th> <th rowspan="3">※ : DON'T CARE</th> </tr> </thead> <tbody> <tr> <td>H</td> <td>※</td> <td>NTSC</td> </tr> <tr> <td>L</td> <td>H</td> <td>MESECAM</td> </tr> <tr> <td>L</td> <td>L</td> <td>PAL</td> <td></td> </tr> </tbody> </table>	NTSC/PAL	MESECAM/PAL	MODE	※ : DON'T CARE	H	※	NTSC	L	H	MESECAM	L	L	PAL		H or L H or L		
NTSC/PAL	MESECAM/PAL	MODE	※ : DON'T CARE																	
H	※	NTSC																		
L	H	MESECAM																		
L	L	PAL																		
17	—	—	Unused (pulled up).	—																
18	—	—	Unused (pulled up).	—																
19	DEW-SENSOR (fixed at "H")	I	Receives a signal from the dew sensor circuit and prevents mechanical operation in the high humidity state.	L																
20	$\overline{\text{REC-PROOF}}$	I	Detects the presence/absence of the mis-erasure prevention tab. "H" : No tab "L" : Tab	L																



Pin No.	Pin Name	I/O	Description	Active															
21	—	—	Unused.	—															
22	VCR/TV	O	Switches the RF signal output of the VCR. "H" : Built-in RF converter signal output "L" : External antenna signal output	H or L															
23	LINE/TUNER (AUDIO)	O	Switches the audio output. "H" : Line input audio "L" : Tuner audio	H or L															
24	LINE/TUNER (VIDEO)	O	Switches the video output. "H" : Line input video "L" : Tuner video	H or L															
25	EX	I	A ceramic oscillator which generates the system clock signal (6MHz) is connected to these pins.																
26	X	O																	
27	RST	I	System reset input.	L															
28	—	—	Unused.	—															
29	—	—	Unused (pulled up).	—															
30	SCK	I	Receives a pulse to time writing/reading of the serial data to/from the timer microprocessor.	Pulse															
31	SI	I	Signal for receiving serial data from the timer microprocessor.	H or L															
32	GND	—	GND.	—															
33	SO	O	Signal to output serial data to the timer microprocessor.	H or L															
34	DRUM-ON	O	Drum motor rotation/stop control.	L															
35	DELAYED-REC	O	Outputs "H" after the tape transport and the capstan speed are stabilized when the stop mode is switched to the record mode and the record pause mode is switched to the record mode, to instruct recording of a signal on the tape.	H															
36	—	—	Unused.	—															
37	A-MUTE	O	Mutes an audio signal. A) Outputs "H" during trick play. B) Outputs "H" for the specified period before and after the EE output is inverted to cut off the noise occurring when switching between the tape recording signal and EE signal (when the EE output is inverted).	H															
38	CM-R	O	Capstan motor rotation/stop and rotation direction control outputs. <table border="1" style="margin-left: 20px;"> <thead> <tr> <th>CM-F</th> <th>CM-R</th> <th>State</th> </tr> </thead> <tbody> <tr> <td>L</td> <td>L</td> <td>Motor stopped</td> </tr> <tr> <td>H</td> <td>L</td> <td>Rotates forward</td> </tr> <tr> <td>L</td> <td>H</td> <td>Rotates in reverse</td> </tr> <tr> <td>H</td> <td>H</td> <td>Braking stopped</td> </tr> </tbody> </table>	CM-F	CM-R	State	L	L	Motor stopped	H	L	Rotates forward	L	H	Rotates in reverse	H	H	Braking stopped	H
CM-F	CM-R	State																	
L	L	Motor stopped																	
H	L	Rotates forward																	
L	H	Rotates in reverse																	
H	H	Braking stopped																	
39	CM-F	O	H																
40	TLM-R	O	Tape sledding motor rotation/stop and rotation direction control outputs. <table border="1" style="margin-left: 20px;"> <thead> <tr> <th>TLM-F</th> <th>TLM-R</th> <th>State</th> </tr> </thead> <tbody> <tr> <td>L</td> <td>L</td> <td>Motor stopped</td> </tr> <tr> <td>H</td> <td>L</td> <td>Rotates forward</td> </tr> <tr> <td>L</td> <td>H</td> <td>Rotates in reverse</td> </tr> <tr> <td>H</td> <td>H</td> <td>Braking stopped</td> </tr> </tbody> </table>	TLM-F	TLM-R	State	L	L	Motor stopped	H	L	Rotates forward	L	H	Rotates in reverse	H	H	Braking stopped	H
TLM-F	TLM-R	State																	
L	L	Motor stopped																	
H	L	Rotates forward																	
L	H	Rotates in reverse																	
H	H	Braking stopped																	
41	TLM-F	O	H																

Pin No.	Pin Name	I/O	Description	Active
42	CAPSTAN-SPEED-HOLD	O	Outputs "H" when the tape sledding motor moves among the REVERSE, PLAY and PINCH OFF positions accompanying the transition between PLAY and REVIEW from REC to REC PAUSE. Outputs "H" during STILL and PAUSE to hold the capstan speed so the capstan servo circuit can easily be returned to the play speed.	H
43	FF/REW	O	Outputs "H" during FF/REW, cassette-in and out operations and during unloading from PLAY to STOP. Controls the high-speed rotation of the capstan motor.	H
44	REV	O	Unused. Outputs "H" during REVIEW. Controls the review speed of the servo circuit.	H
45	CUE	O	Unused. Outputs "H" during CUE. Controls the cue speed of the servo circuit.	H
46	STILL-ADVANCE	O	Unused. Outputs "H" during STILL ADVANCE.	H
47	STILL/PAUSE	O	Unused. Outputs "H" during STILL, REC PAUSE and S-ADV.	H
48	PLAY	O	Unused. Outputs "H" during PLAY, STILL, CUE, REV and S-ADV.	H
49	REC	O	Unused. Outputs "H" during REC and REC PAUSE.	H
50	REW	O	Unused. Outputs "H" during REW and REV.	H
51	FF	O	Unused. Outputs "H" during FF and CUE.	H
52	—	—	Unused.	—
53	DELAYED-PLAY	O	Outputs "H" after the tape transport and capstan speed are stabilized when STOP is switched to PLAY and STOP is switched to STILL, to prevent picture distortion.	H
54	REQUEST	O	Signal to request serial communications to the timer microprocessor.	L
55	READY	O	Signal to inform the timer microprocessor that the standby for serial data reception is completed.	L
56	S-CLK	O	Outputs a pulse to time the writing of serial data to the servo IC.	Pulse
57	S-DAT	O	Signal to output serial data to the servo IC.	H or L
58	EE	O	Switches the video output between the external input signal and tape playback signal. "H" : External input signal "L" : Tape playback signal	H
59	—	—	Unused.	—
60	TRKG RST	O	Outputs a pulse of approx. 5ms when the POWER, EJECT or REC key is pressed to reset the tracking microprocessor.	H
61	JOG	O	Outputs "H" during CUE and REV.	H
62	SYNC	I	Signal to synchronize serial communications with the timer microprocessor.	L
63	—	—	Unused.	—
64	EVER +5V	—	Positive power supply pin.	—

IC,  $\mu$ PD75208CW-A25 (IC901)

Pin No.	Pin Name	I/O	Description	Active
1	D	O	Anode and key matrix signals for the fluorescent display tube.	Pulse
2	C	O		
3	B	O		
4	A	O		
5	TEST	I	Input for the test mode of the unit.	L
6	TUSCK	I	Receives a pulse to time the writing/reading of serial data to/from the tuner microprocessor.	Pulse
7	TUSO	O	Signal to output serial data to the tuner microprocessor.	H or L
8	TUSI	I	Signal for receiving serial data from the tuner microprocessor.	H or L
9	REMOCON	I	Remote control data input.	Pulse
10	REEL-PULSE	I	Receives a signal from the reel sensor in the deck mechanism. Receives reel pulses for the tape counter. When 4 pulses are input, the counter counts up by one step.	Pulse
11	24h/12h	I	Switches the clock indication. "H" : 24 hours "L" : 12 hours AM/PM	H or L
12	SI	I	Signal to receive serial data from the mechanism microprocessor.	H or L
13	SCK	O	Receives a pulse to time the writing/reading of serial data to/from the mechanism microprocessor.	Pulse
14	SO	O	Signal to output serial data to the mechanism microprocessor.	H or L
15	TUCS	O	Outputs a signal to request serial communications to the tuner microprocessor.	H
16	BUZZER	O	Output signal (approx. 2kHz) to drive the buzzer.	Pulse
17	REQUEST	I	Receives a signal to request serial communications from the mechanism microprocessor.	L
18	READY	I	Receives a signal from the mechanism microprocessor which signals that the standby for serial data reception is completed.	L
19	SYNC	O	Signal to synchronize serial communications with the mechanism microprocessor.	L
20	P.ON	O	Controls the power supply circuit of the VCR. Power is turned on.	H
21	KM 0	I	Key matrix scan input.	Pulse
22	KM 1	I	Key matrix scan input.	Pulse
23	KM 2	I	Key matrix scan input.	Pulse
24	KM 3	I	Key matrix scan input.	Pulse
25	LP-H	I	Tape speed mode. Tape speed is LP.	H
26	EP-H	I	Tape speed mode. Tape speed is EP.	H
27	TV/VCR	I	Selects the indication in the fluorescent display of the VCR. "H" : Displays information. "L" : Does not display information.	H
28	SERVICE	I	Input for the service mode of the VCR.	L
29	PPO	-	Unused.	-
30	EX	I	A ceramic oscillator which generates a main system clock pulse (4.19MHz) is connected.	
31	X	O		

Pin No.	Pin Name	I/O	Description	Active
32	GND	-	GND.	-
33	EXT	I	A crystal oscillator which generates a sub-system clock pulse (32.768KHz) is connected.	
34	XT	O		
35	POWER LED	O	Outputs "H" when power is turned on.	H
36	---	-	Unused.	-
37	---	-		
38	---	-		
39	RST	I	System reset input.	L
40	G10	O	Grid signals of the fluorescent display tube.	Pulse
41	G9	O		Pulse
42	G8	O		Pulse
43	G7	O		Pulse
44	G6	O		Pulse
45	G5	O		Pulse
46	G4	O		Pulse
47	G3	O		Pulse
48	G2	O		Pulse
49	G1	O		Pulse
50	---	-	Unused.	-
51	---	-		
52	---	-		
53	---	-		
54	---	-		
55	---	-		
56	EVER -30V	I	The pull-down resistors of the FIP controller/driver are connected.	
57	EVER -3V	I	Supplies power to the output buffer of the FIP controller/driver.	
58	J	O	Anode signals of the fluorescent display tube.	Pulse
59	I	O		Pulse
60	H	O	Anode and key matrix signals for the fluorescent display tube.	
61	G	O		
62	F	O		
63	E	O		
64	EVER +5V	-	Positive power supply.	-

IC. HD404302A06P (IC207)

Pin No.	Pin Name	I/O	Description
1	---	-	Unused (fixed at "H").
2	AUTO/MAN	I	Auto tracking on/off signal ("H" in the AUTO Mode).
3	---	-	Unused (fixed at "H").
4	---	-	Unused (fixed at "L").
5	TR LED	O	Outputs pulses to make the LED flash during search in the auto tracking mode, and outputs "H" after auto tracking is completed.
6	TR MM	O	Outputs a delay timing pulse during auto tracking.
7	---	-	Unused.
8	C CONT 2	O	Outputs a noise feed pulse in the noise cancelling mode.
9	---	-	Unused.
10	TR CONT	O	Outputs "L" during auto tracking to switch the TR MM circuit to the AUTO side.
11	D RST	O	Outputs a reset pulse to detect the noise position in the noise cancelling mode.
12	---	-	Unused.
13	RF SW	I	RF SWP input.
14	---	-	Unused (fixed at "H").
15	CTL	I	CTL shaped wave form input.
16	---	-	Unused (fixed at "H").
17	---	-	Unused (fixed at "L").
18	---	-	Unused (fixed at "L").
19	M RF SW	I	RF SWP input.
20	DOC P	I	Noise position detection signal for the noise canceller.
21	GND	-	Power supply (GND).
22	A VCC	-	Power supply (+5V) of A/D converter.
23	V LEV	I	Input to detect the amplitude of the video signal during auto tracking (Analog DC).
24	---	-	Unused (fixed at "L").
25	---	-	Unused (fixed at "L").
26	---	-	Unused (fixed at "L").
27	A VSS	-	Power supply (GND) of A/D converter.
28	RESET	I	Reset input (goes "H" when reset).
29	---	-	Unused (fixed at "H").
30	EX	-	} A clock generator is connected to these pins.
31	X	-	
32	VCC	-	Power supply (+5V).
33	---	-	Unused.
34	NTSC/PAL	I	NTSC/PAL selection (fixed at "L").
35	---	-	Unused (fixed at "H").
36	---	-	Unused (fixed at "L").
37	JOG	I	"H" is input during CUE/REV.
38	PAUSE	I	Detects STILL ("H") and cancels noise.
39	MOD 1	I	} These pins detect the tape speed mode.
40	MOD 0	I	
41	V PB	I	"H" is input during PLAV.
42	---	-	Unused.

IC, MN67481P (IC203)

Pin No.	Pin Name	I/O	Description												
1	VDD	-	Power supply (+5V) of digital section.												
2	TR MM	I	Tracking monostable multivibrator. Delay time constant for CTL locking position adjustment.												
3	SDAT	I	Servo mode setting data input.												
4	SCLK	I	Servo mode setting clock input.												
5	RCLK	I	Reference timing clock for servo control (PAL : 4.433618MHz).												
6	TEST	I	Unused (fixed at "L").												
7	VLP	O	Artificial VD output (only during CUE, REV and STILL).												
8	MOD 0	O	} Record mode output.												
9	MOD 1	O													
<table border="1" style="margin-left: auto; margin-right: auto;"> <thead> <tr> <th></th> <th>MODE 0</th> <th>MODE 1</th> </tr> </thead> <tbody> <tr> <td>SP mode 3H</td> <td>"L"</td> <td>"L"</td> </tr> <tr> <td>LP mode 3H</td> <td>"H"</td> <td>"L"</td> </tr> <tr> <td>EP mode 6H</td> <td>"H"</td> <td>"H"</td> </tr> </tbody> </table>					MODE 0	MODE 1	SP mode 3H	"L"	"L"	LP mode 3H	"H"	"L"	EP mode 6H	"H"	"H"
	MODE 0	MODE 1													
SP mode 3H	"L"	"L"													
LP mode 3H	"H"	"L"													
EP mode 6H	"H"	"H"													
10	RF SW P	O	RF SW P output (PAL : 25Hz).												
11	PWM 2	O	Drum servo phase error output.												
12	PWM 1	O	Drum servo speed error output.												
13	PWM 3	O	Capstan servo speed error output.												
14	PWM 4	O	Capstan servo phase error output.												
15	VSS	-	Power supply (GND) of digital section.												
16	YPG	I	Drum PG amplifier input.												
17	YFG	I	Drum FG amplifier input.												
18	FGI	I	Capstan FG amplifier input.												
19	RI	I	Sets the reference neutral point voltage (+2.5V) of the internal linear amplifier.												
20	VRO	O	Reference voltage (set by pin 19) output.												
21	CI	I	CTL clamp input.												
22	CO	O	CTL amplifier output.												
23	CTLG	-	CTL amplifier GND.												
24	CTLA	I	Sets the CTL amplifier gain (negative input terminal).												
25	CTLH	I	CTL input.												
26	A VDD	-	Power supply (+5V) of analog section.												
27	V SYN	I	Vertical sync signal input.												
28	PG MM	I	Switching position monostable multivibrator. Delay time constant for head switching point adjustment.												

IC,  $\mu$ PDI730CT (IC881)

Pin No.	Pin Name	I/O	Description												
1	OSC 1	I	4.5MHz ceramic oscillator input.												
2	OSC 2	O	4.5MHz ceramic oscillator output.												
3	PPO	O	D/A converter PWM output (tuning voltage).												
4	CSYNC	I	H. sync pulse input (sync detection input).												
5	AFT	I	AFT voltage input.												
6	VDD	-	+5V power supply.												
7	---	-	Unused.												
8	AUS	I	Signal to select the destination, Australia.												
9	CS	O	E <sup>2</sup> PROM chip select.												
10	EUSI	I	E <sup>2</sup> PROM serial data input.												
11	EUSO	O	E <sup>2</sup> PROM serial data output.												
12	TUSO	O	Serial data output (input to the tuner).												
13	TUCS	I	Data transfer trigger.												
14	GND	O	GND.												
15	POWER ON	I	POWER key signal.												
16	---	-	Unused.												
17	AFTC	O	AFT control.												
18	AFTC	O	AFT control.												
19	TUMU	O	Goes "H" when muting a signal.												
20	TUMTC	O	Goes "L" when H. sync pulse is detected.												
21	---	-	Unused.												
22	---	-	Unused.												
23	GND	-	GND.												
24	RESET	I	Goes "H" at the program start.												
25	TUSI	I	Serial data input (output from the tuner).												
26	TUSCK	O	Serial data clock.												
27	ROMCLK	O	E <sup>2</sup> PROM clock.												
28	BAND 1	O	} These pins assign the tuner band.												
29	BAND 2	O													
<table border="1" style="float: right; margin-left: 20px;"> <thead> <tr> <th>BAND</th> <th>BAND1</th> <th>BAND2</th> </tr> </thead> <tbody> <tr> <td>VH</td> <td>1</td> <td>0</td> </tr> <tr> <td>VL</td> <td>0</td> <td>1</td> </tr> <tr> <td>U</td> <td>1</td> <td>1</td> </tr> </tbody> </table>				BAND	BAND1	BAND2	VH	1	0	VL	0	1	U	1	1
BAND	BAND1	BAND2													
VH	1	0													
VL	0	1													
U	1	1													
30	---	-	Unused.												

# CIRCUIT DESCRIPTION

## 1. AUTO TRACKING

When the VCR is in a play mode other than the JOG (CUE/REV) and STILL modes, this function operates by turning AUTO TRACKING on (IC207 pin ②: High).

### (Function devices)

IC207, Q450, Q451, Q210, Q211, Q212 and peripheral capacitors and resistors.

### (Principle)

The tracks are traced so that the CTL signal (which is delayed = TR MM) is servo-locked during play. However, the CTL heads have tolerances within the specification in different mechanisms, therefore, TR MM (tracking control) is adjusted with ordinary VCRs and the CTL signal is set to the optimum position.

The auto tracking function detects the level of the signals output from the video heads and sets the delay from the CTL signal so that the level is maximum. Auto tracking is performed through the following three processes.

1. Search ... Detects the position where the level is maximum.
2. FIX ..... Fixes the delay so that the level is optimum.
3. Monitoring the change ... Detects whether or not the recording state was changed, and if a change is detected, searching re-started.

### (Operation)

#### 1. Search

- a. When a cassette is loaded and the VCR first enters the play mode.
  - b. When the recording state was changed and the head output level changes (change of  $\pm 1/8$  or more from the design value).
  - c. When there are non-signal recorded sections and recorded sections due to a change of recording state.
- When the auto tracking circuit detects one of the following items, a, b and c, it performs searching and controls the delay from the CTL signal in steps so that the head output level is maximum.

Since the read levels vary as shown in the diagram below due to different rotation angles of the drum heads, the read timing is specified from RF SWP and the average read data is detected to improve reliability.

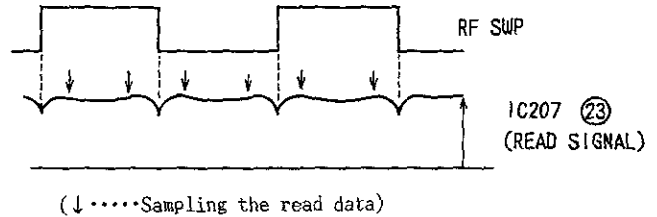

#### 2. Fixing

The delay is varied by the auto compulsory tracking MM (Q210, Q211, Q212) and the signal levels at each delay time are read. When the maximum level is detected, it is stored in memory and the delay is fixed. The data of the tape with which search is completed is stored until ejection of power off is performed and the VCR enters the AUTO mode at the start of play without passing through search even when the stop mode is entered.

#### 3. Monitoring of changes

The auto tracking circuit always monitors an abnormality even if the delay is fixed in the AUTO mode, and if any change occurs, it repeats search to adjust the tracking for the best.

(Note) The LED does not light in the following case even if the auto tracking switch is turned on.  
When a tape with no signal recorded on it is played.  
(presence/absence of CTL signal)

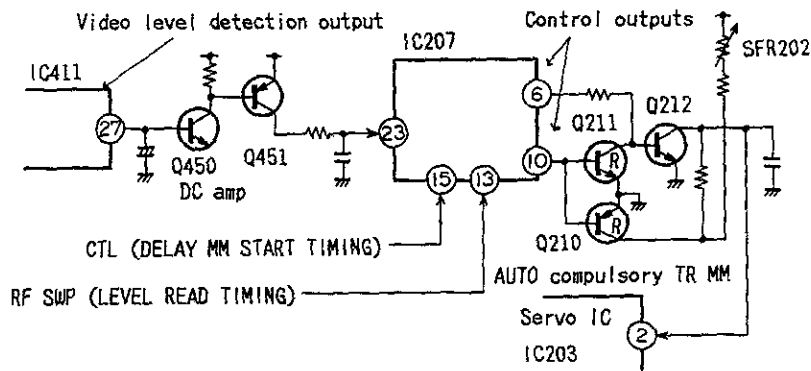

## 2. AUTO NOISE CANCELLER

When the STILL button is pressed during play, the auto noise canceller drives noise bars out of the screen so that they are not visible.

### [Function devices]

IC207, IC209, Q213, Q214

### [Conditions]

IC207 determines whether the auto cancelling function should be operated or not and executes operation.

1. IC207 (41) High (PB)
2. IC207 (38) High (PAUSE)

### [Principle]

The position of the noise bar can be known from the DOC P waveform in the video circuit. If the DOC P waveform is in area (a) of the RF SWP pulse as shown in the diagram below, the noise bar is not visible on the TV screen. The following DOC P pulse is produced so that IC207 (microprocessor) can read it easily.

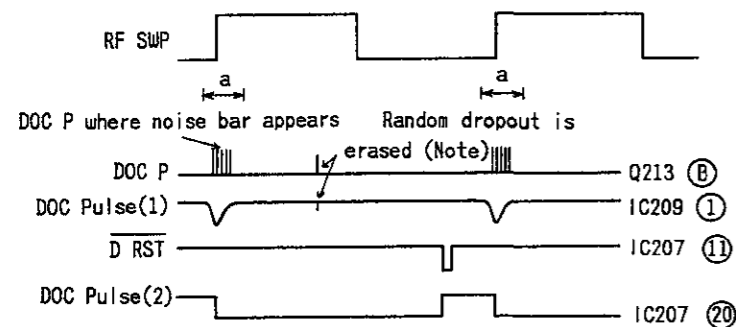

1. When the trailing edge of the DOC P Pulse is within range (a) in the STILL mode, the cancelling operation is not necessary.
2. When it is out of range (a), the pulse which turn the capstan motor minutely are generated at pin 8 of IC207.
3. When the tape is fed minutely and the trailing edge of the DOC P pulse enters area (a), the generating of pulses is stopped.

The DOC pulse moves to the right with reference to the RF SWP pulse in steps 2 and 3.

(Note) When tapes with large random dropouts are used, the random dropouts and DOC pulses cannot be discriminated and the unit performs the detection erroneously.

## ELECTRICAL ADJUSTMENT

### Preparation for adjustment

Input signal (100% white)

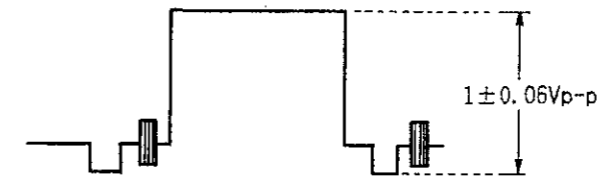

※Note : Voltage measured with a signal generator connected to the VCR

Input signal (color bar)

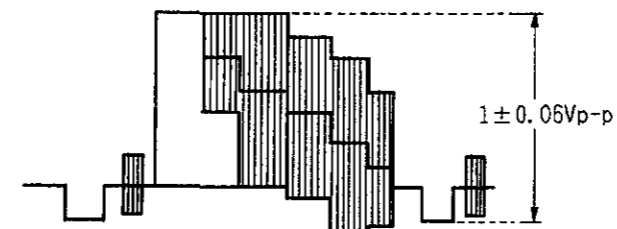

※Note : Voltage measured with a signal generator connected to the VCR

Connections of test equipment

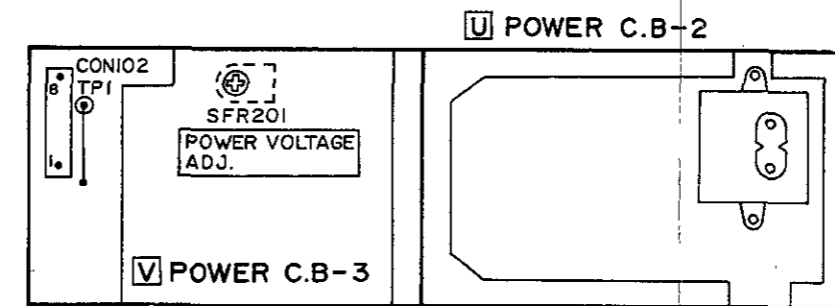
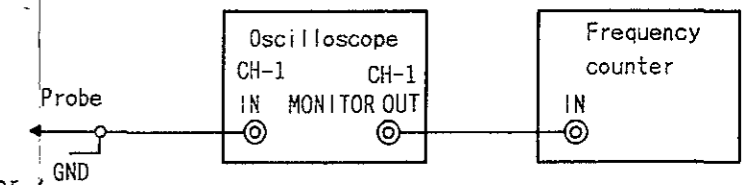

### 1. Power voltage adjustment ( U POWER C.B.-2)

- 1) Connect a digital tester between pin 5 (TP1) of CON102 on the main circuit board and ground.
- 2) Adjust SFR201 on the POWER C.B.-2 so that the voltage is  $12.2V \pm 0.1V$ .

### D TIMER C.B (COMPONENT SIDE)



### 2. Clock frequency adjustment

(for the clock) ( D TIMER C.B)

Frequency counter : Connected to oscilloscope monitor terminal of frequency counter.  
IC901 pin (34) (TP901)

- 1) Turn the power on.
- 2) Adjust TC901 so that the frequency is within the specification,  $32.768kHz \pm 0.0025Hz$ .

**B SERVO/SYSCON C.B (COMPONENT SIDE)**

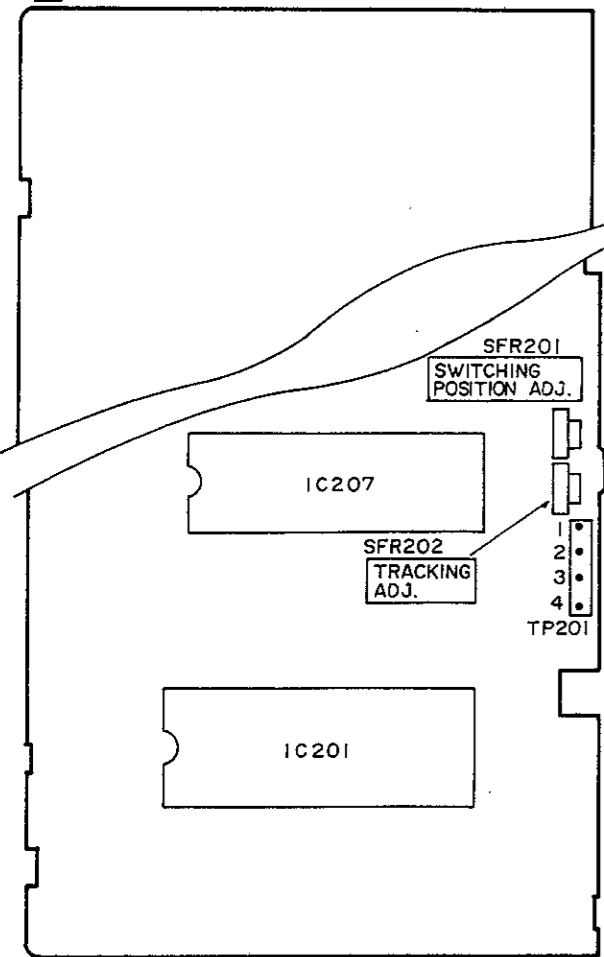

**3.Servo circuit adjustment**

- (1) Tracking Adjustment ( **B** SERVO/SYSCON C.B)  
 Oscilloscope CH-1 : TP201 pin ② (RF SWP)  
 CH-2 : TP201 pin ① (CTL)
- 1) Set the VCR to the manual tracking mode.
  - 2) Set RV901 (tracking VR) to the center position.
  - 3) Play alignment tape TTV-P1.
  - 4) Adjust SFR202 so that the position of the CTL signal is as shown in the figure below.

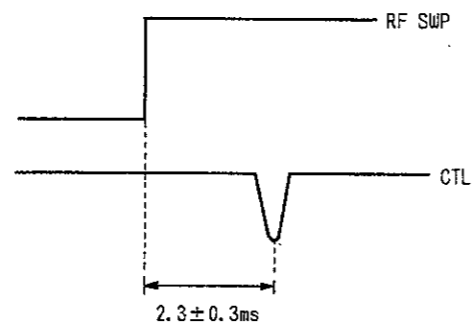

- (2) Switching Position Adjustment ( **B** SERVO/SYSCON C.B)

- Oscilloscope CH-1 : TP201 pin ② (RF SWP)  
 CH-2 : TP201 pin ③ (V SYNC)
- 1) Set the VCR to the manual tracking mode.
  - 2) Set RV901 (tracking VR) to the center position.
  - 3) Play alignment tape TTV-P1.
  - 4) Adjust SFR201 so that the V. SYNC signal is as shown in the figure below.

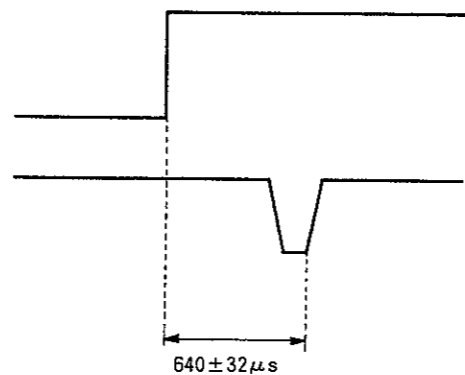

**A MAIN C.B (PATTERN SIDE)**

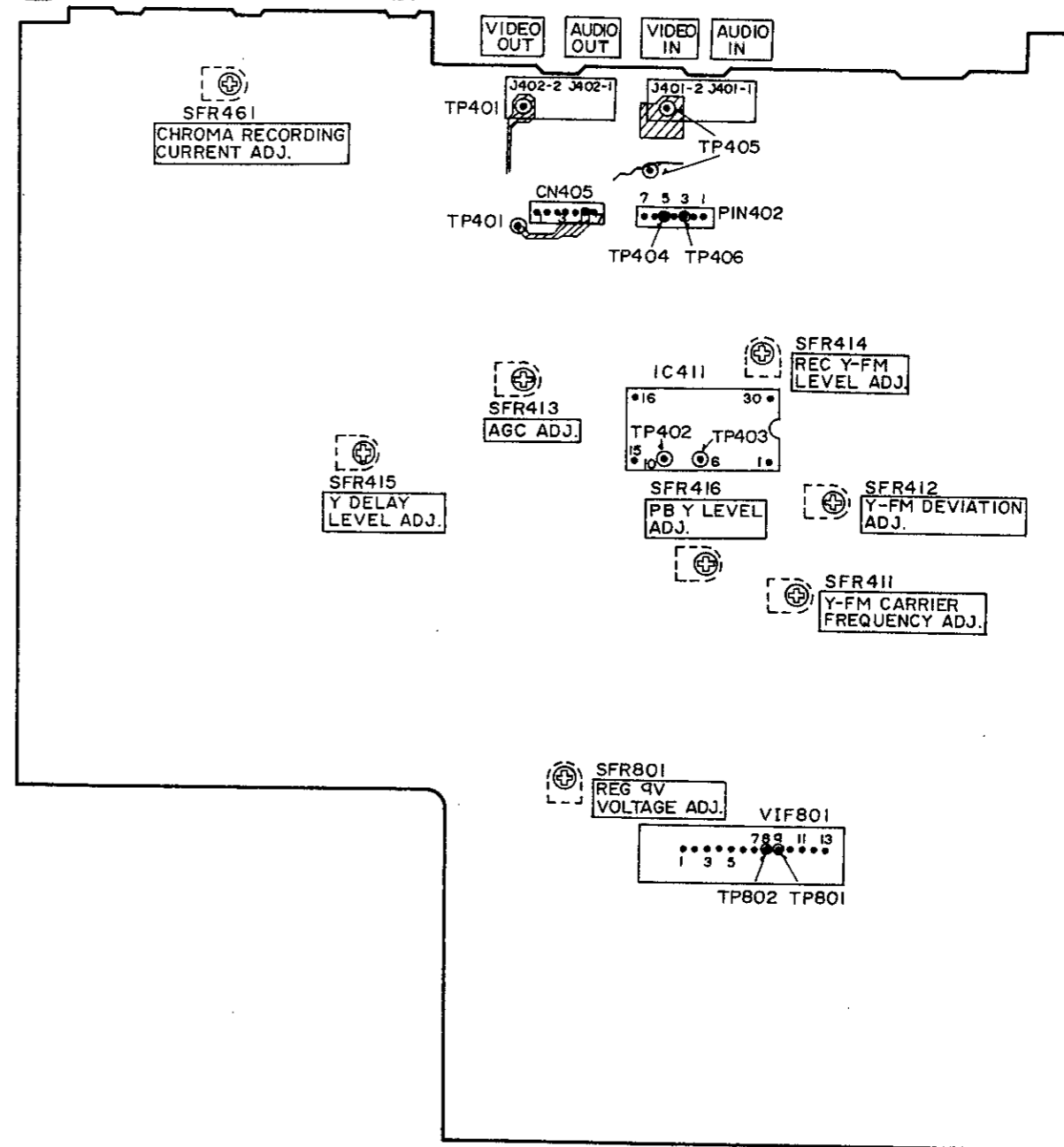

**4.Video circuit adjustment**

- (1) PB Y Level Adjustment ( **A** MAIN C.B)

- Oscilloscope : VIDEO OUT (TP401)
- 1) Play alignment tape TTV-P1.
  - 2) Adjust SFR416 so that the white 100% level is as shown in the figure below.
- ※Terminate the VIDEO OUT jack with 75ohms or connect a monitor to it.

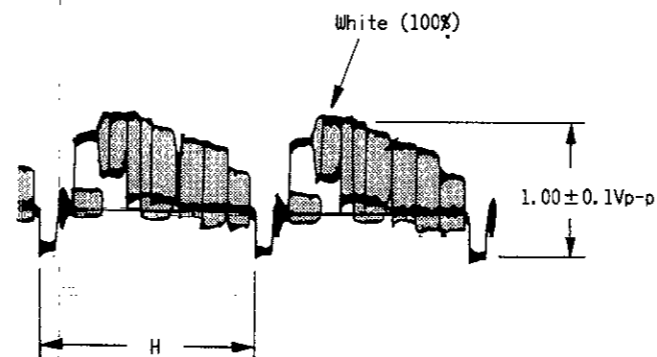

- (2) Y Delay Level Adjustment ( **A** MAIN C.B)

- Oscilloscope : IC411 pin ⑩ (TP402)
- 1) Play alignment tape TTV-P1.
  - 2) Adjust SFR415 so that the level at pin ⑩ of IC411 is the same as that of the waveform at pin ⑨ of IC301.

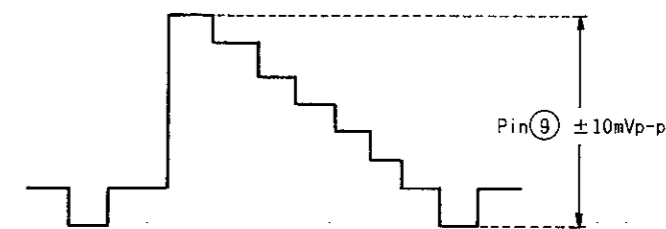



# MECHANICAL ADJUSTMENT

## 1. TAPE TRANSPORT ADJUSTMENT FLOWCHART

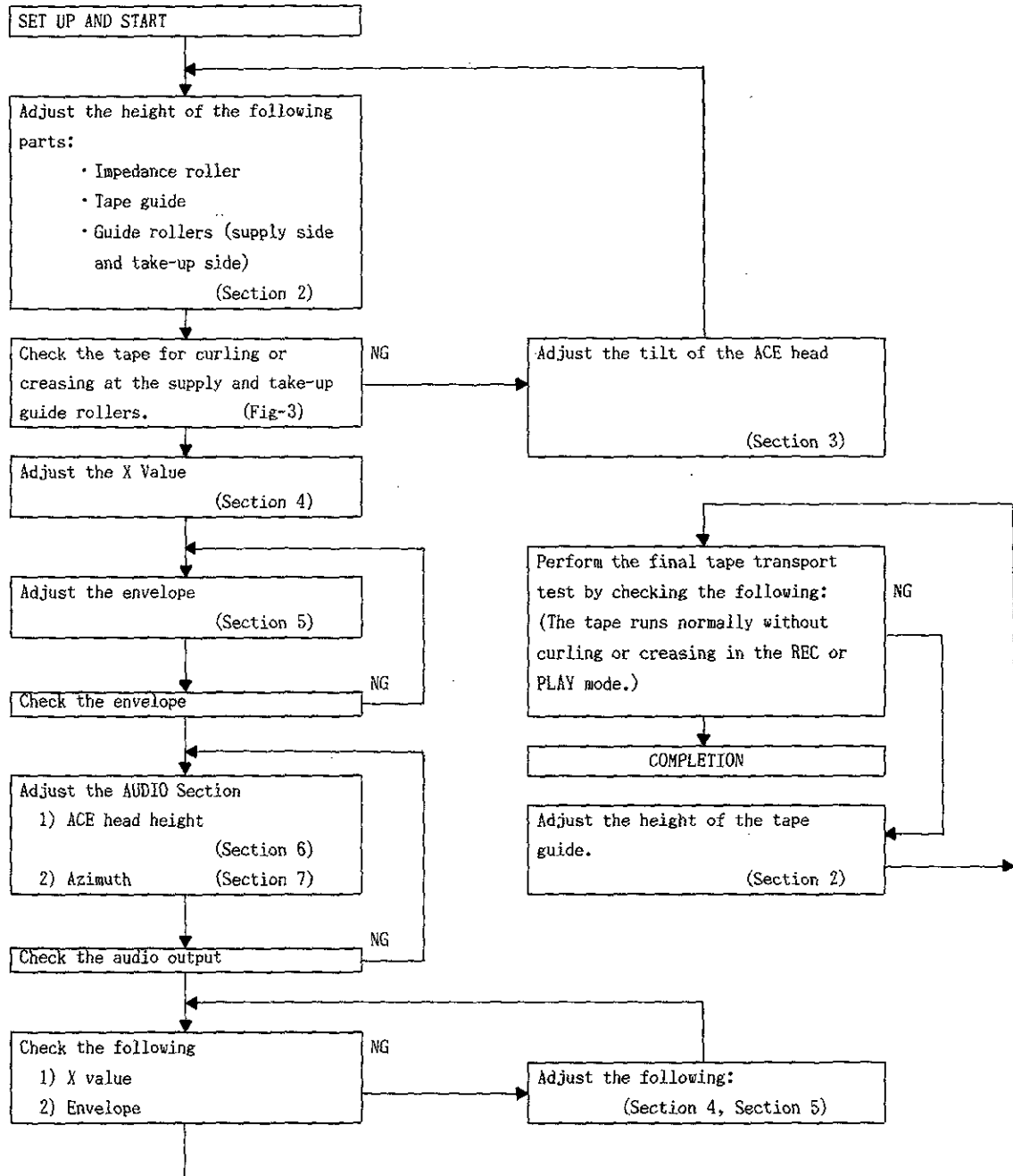

## 2. TAPE RUNNING POSITION ADJUSTMENT (GUIDE ROLLER/TAPE GUIDE/IMPEDANCE ROLLER)

### Set-up

Lift the "Main circuit board".

1. Perform the height adjustment for the following items to obtain the proper tape running position. (See Figure-1)

- ① Impedance roller
- ② Guide roller (Supply side)
- ③ Guide roller (Take-up side)
- ④ Tape guide

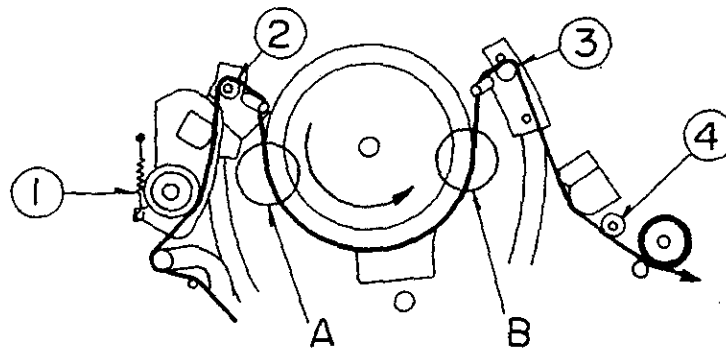

Fig-1

2. Load a blank tape and set it to the PLAY mode. Check the tape transport at points "A" and "B" as shown in Fig-1.

3. Operate it between the PLAY and STOP modes several times.

4. Observe the tape transport at the "Lead surface of the cylinder" during the PLAY mode, and confirm that the tape runs smoothly along the "Lead surface of the cylinder" without slipping downward or upward. (See Figure-2)

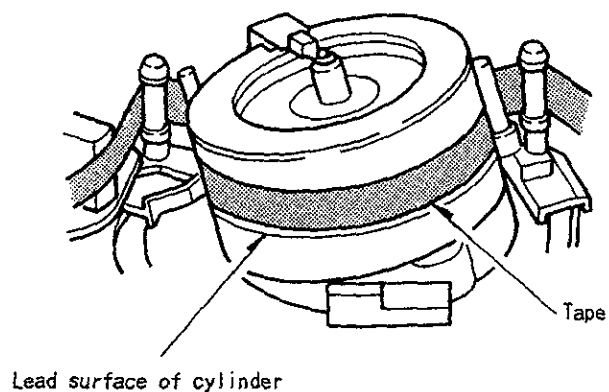

Fig-2

5. During loading, play and unloading, observe the tape at the supply and take-up "Guide rollers", "Tape guide" and "Impedance roller". Confirm that there is no curling or creasing etc., as shown in Fig-3.

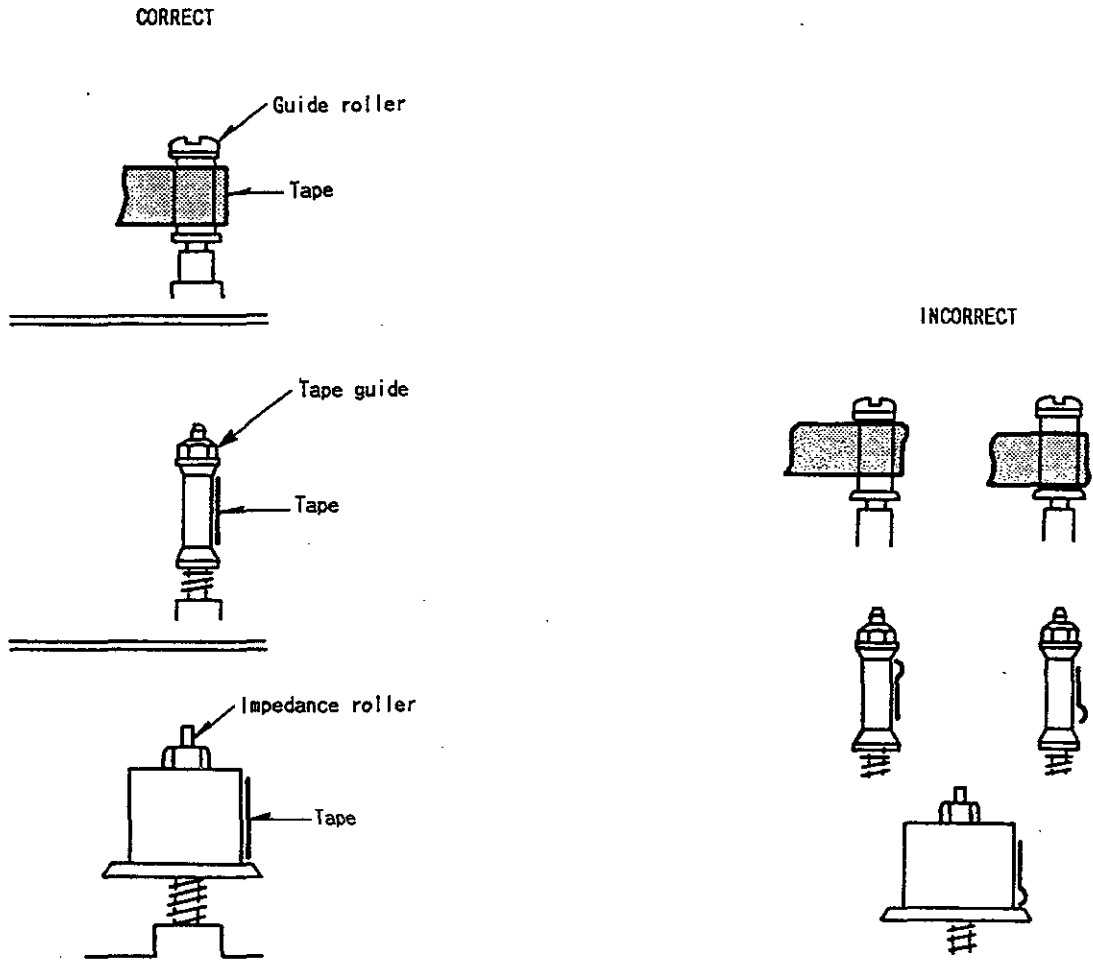

Fig-3

6. If any curling or creasing is noted, adjust "Tape guide roller" and "Impedance roller" first. In this case, adjust the "Impedance roller" in both PLAY and REV modes so that the tape runs as shown in Fig-4.

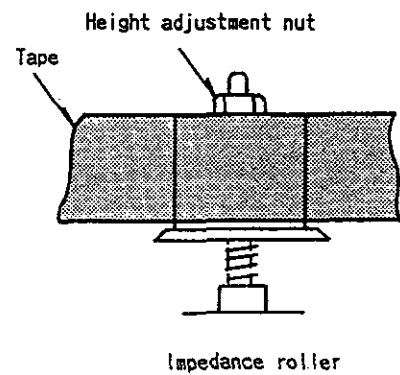

Fig-4

7. Next, adjust the "Guide roller" height. Insert the adjustment driver (J2) into the "Guide roller" top.

(See Figure-5)

Adjust the height by turning the driver slightly so that the tape runs on the "Guide roller" as shown in Fig-3, and the lower edge of the tape runs along the "Lead surface of the cylinder".

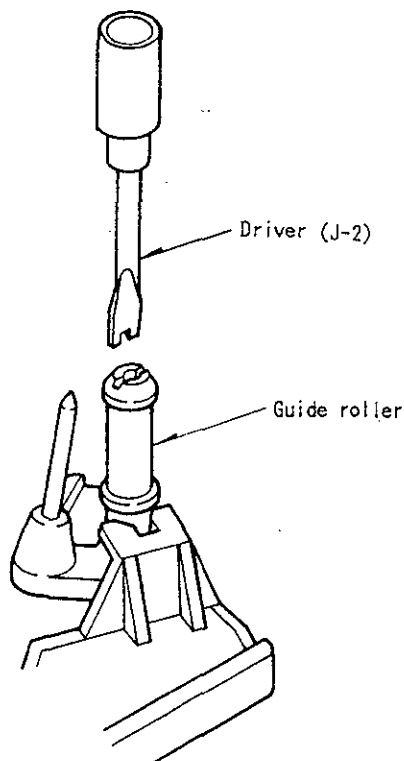

Fig-5

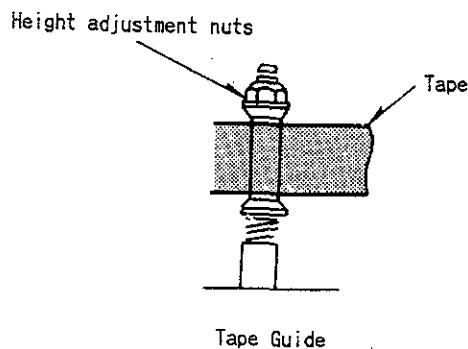

Fig-6

8. After completion of the supply side "Guide roller" adjustments, adjust "Tape guide" so that tape runs as shown in Fig-6 and adjust the take-up side "Guide roller" by using the same procedures as for the supply side adjustments.

In this case, adjust the "Guide roller" height first.

9. Confirm that there is no curling or creasing at the "Impedance roller" (Both PLAY and REV modes). If there is any curling or creasing at the "Impedance roller", adjust the same procedures of Fig-6.

10. Finally, confirm that there is no curling or creasing at the take-up side guide roller and tape guide. If there is any curling or creasing between the take-up side "Guide roller" and the "ACE head", adjust the "ACE head".

### 3. ACE HEAD ADJUSTMENT

1. Load a recorded tape and set the it to PLAY mode.
2. Adjust the height of the edge of the "Audio track" on the "Audio control head" by using the height adjustment nut (A) and the "Tilt adjustment screw" (C) so that the tape transport is smooth at the "Take-up guide pole". Align the "Audio control head" height. (See Figure-7)

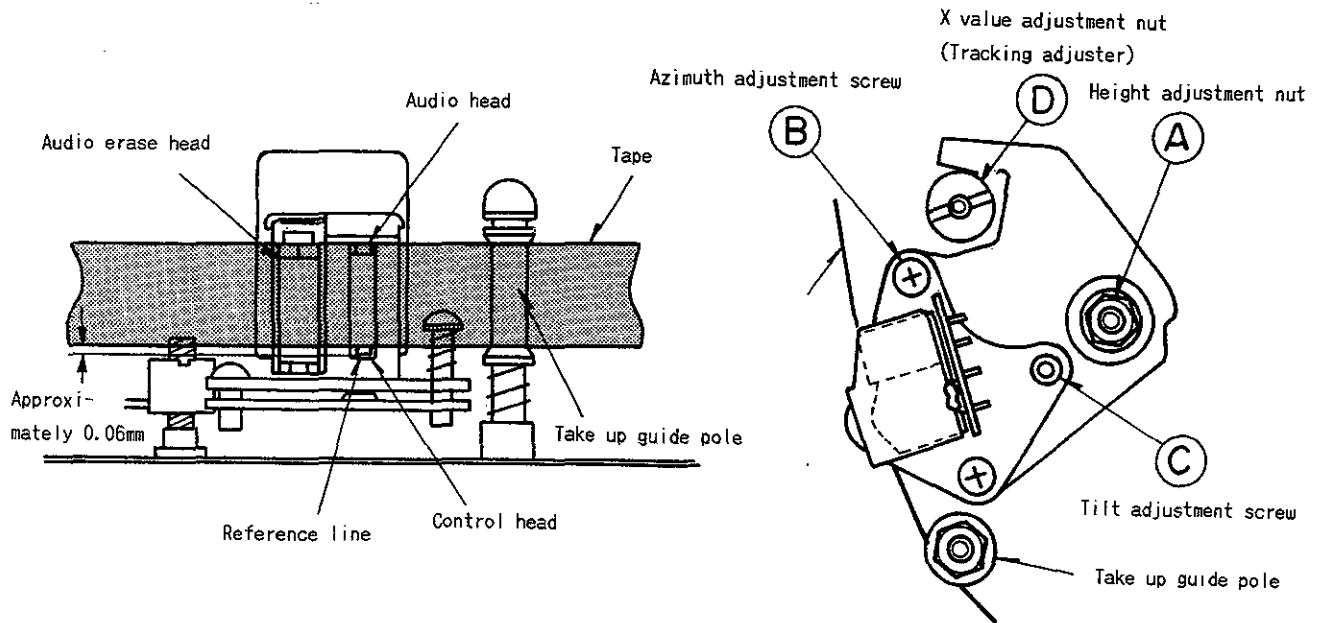

Fig-7

3. The fine adjustment is not required at this time.  
The following conditions are sufficient :
  - (a) Proper tape transport between the "Audio control head" and the "Take-up guide pole".
  - (b) Stable SERVO system operation (proper pickup of tape's recorded control signal).

## 4. X VALUE ADJUSTMENT (PB FM PEAK ADJUSTMENT)

### MEASURING METHOD

Measuring Point	Measuring Equip.	ADJ. Condition
MAIN C.B IC411 26 pin SERVO/SYSCON C.B TP201 2 pin	Oscilloscope	PLAY (SP) MODE Test tape TTV-P2
ADJ. Location		ADJ. Value
X value adjustment nut		Maximum level (CH1 PB Y FM signal)

### TEST EQUIPMENT CONNECTING DIAGRAMS

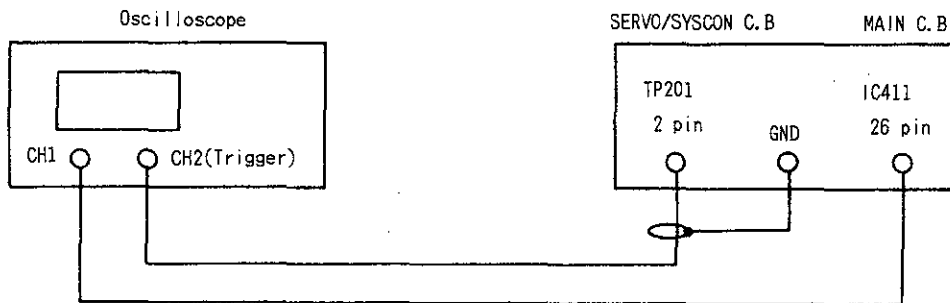

Fig-8

1. Connect the equipment as shown in Fig-8.
2. Adjust RV901 (Tracking volume) to its center position. (clockwise)
3. Adjust the "X value adjustment nut (D)" for maximum PB FM Signal for CH1 by using TTV-P2 test tape. (See Figure-9)
4. After adjusting the "X value", check that the output level of the PB FM Signal for CH1 changes symmetrically by rotating RV901 (Tracking volume).

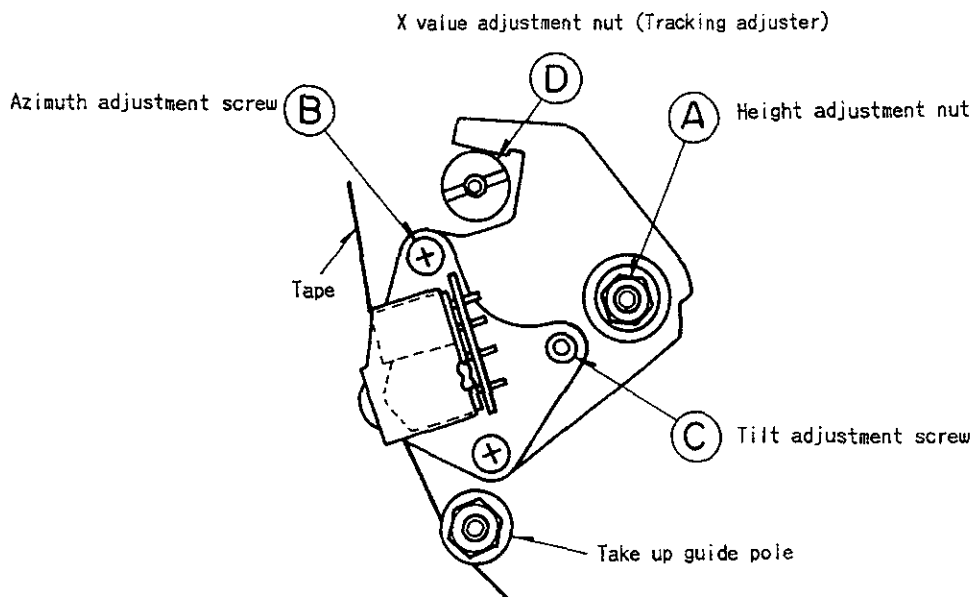
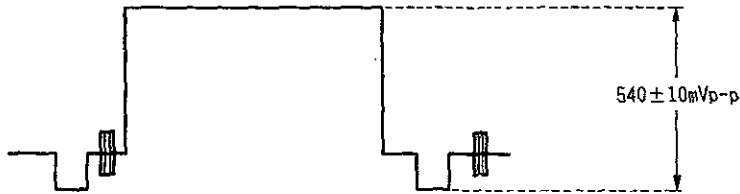

Fig-9

(3) AGC Adjustment ( [A] MAIN C.B)

Oscilloscope : IC411 pin ⑥ (TP403)

- 1) Switch the input selector to LINE.
- 2) Apply a 100% white signal to the VIDEO IN jack.
- 3) Adjust SFR413 so that the Y signal is as shown in the figure below in the E-E mode.



(4) Y-FM Carrier Frequency Adjustment ( [A] MAIN C.B)

Oscilloscope : PIN402 pin ⑤ (TP404)

- 1) Switch the input selector to LINE.
- 2) Set the VCR to the no signal input state (with no input connected to the VIDEO IN jack).
- 3) Set the VCR to the E-E mode.
- 4) Adjust SFR411 so that the frequency counter reads  $3.8MHz \pm 0.05MHz$ .

(5) Y-FM Deviation Adjustment ( [A] MAIN C.B)

※The Y FM carrier frequency adjustment should have been completed.

Oscilloscope : VIDEO OUT (TP401)

- 1) Switch the input selector to LINE.
- 2) Record a 100% white signal.
- 3) Play the recorded section and check the Y signal level.
- 4) If out of specification turn SFR412.
- 5) Repeat 2)~4) until observe the waveform as indicated below.

※Terminate the VIDEO OUT jack with 75ohms or connect a monitor to it.

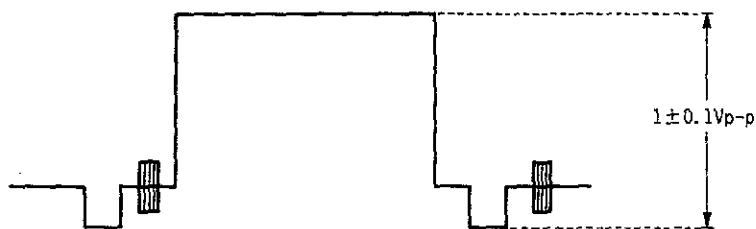

(6) REC Y-FM Level Adjustment ( [A] MAIN C.B)

Oscilloscope CH-1 : PIN402 pin ⑤ (TP404)

CH-2 : VIDEO IN (TP405)

- 1) Switch the input selector to LINE.
- 2) Apply a color bar signal or 100% white signal to the VIDEO IN jack.
- 3) Adjust SFR414 so that the synchro signal level of the Y FM level is as shown in the figure below in the E-E mode.

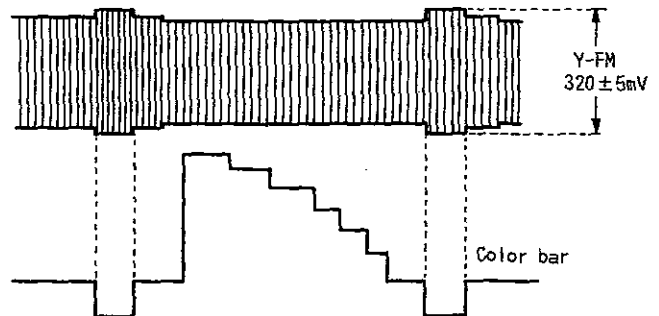

(7) Chroma Recording Current Adjustment ( [A] MAIN C.B)

Oscilloscope : PIN402 pin ③ (TP406)

- 1) Switch the input selector to LINE.
- 2) Apply a color bar signal to the VIDEO IN jack.
- 3) Set the VCR the record mode and adjust SFR461 so that the burst level is as shown in the figure below.

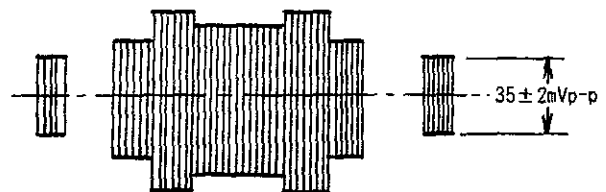

## 5.Tuner section adjustment

(1) REG 9V Voltage Adjustment ( [A] MAIN C.B)

Digital voltmeter Positive terminal : VIF801 pin ⑨ (TP801)

Negative terminal : VIF801 pin ⑧ (TP802)

Adjust SFR801 so that the voltage is within the specification,  $9.00 \pm 0.05V$ .

**C PRE AMP/AUDIO C.B (COMPONENT SIDE)**

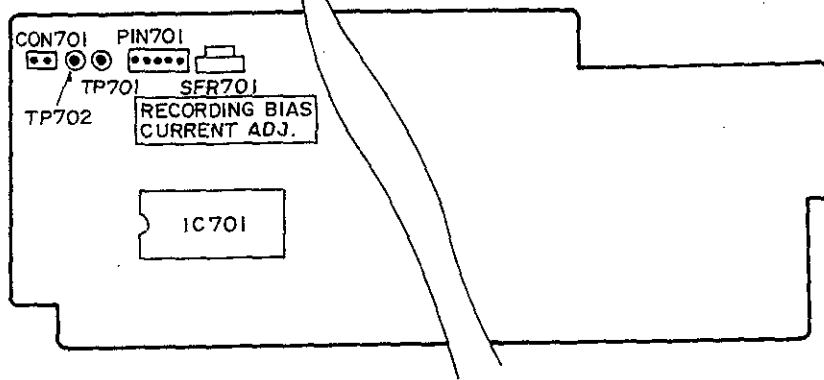

**6.Audio circuit adjustment**

(1) Recording Bias Current Adjustment ( **C** PRE AMP/AUDIO C.B)

VTVM HOT terminal : TP701  
 GND terminal : TP702

- 1) Switch the input selector to LINE.
- 2) Set the VCR to the no signal input state (with no input connected to the LINE AUDIO IN jack).
- 3) Set the VCR to the record mode and adjust SFR701 so that the bias level is within the specification,  $22 \pm 1mVRMS$ .

**TRANSISTOR ILLUSTRATION**



2SA933  
 2SC1740  
 2SC2002  
 2SC3940

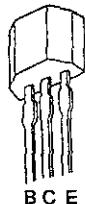

DTA144  
 DTC144



2SA1048

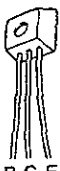

UN4211

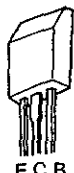

2SB733



2SC4148



## 5. ENVELOPE WAVE FORM ADJUSTMENT

### MEASURING METHOD

Measuring Point	Measuring Equip.	ADJ. Condition
MAIN C.B IC411 26 pin SERVO/SYSCON C.B TP201 2 pin	Oscilloscope	PLAY (SP) MODE Test tape TIV-P2
ADJ. Location		ADJ. Value
Guide rollers		Maximum level and correct waveform (PB Y FM Signal)

### TEST EQUIPMENT CONNECTING DIAGRAMS

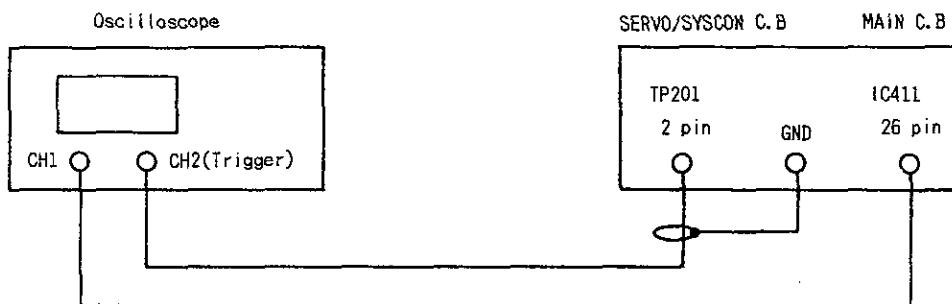

Fig.-10

1. Connect equipment as shown in Fig-10.
2. Playback the test tape TIV-P2.
3. The envelope waveform can be performed by adjusting the height of both the supply side and take-up side "Guide rollers".  
Finally adjust the height of "Guide rollers" so that the envelope waveform is as flat as possible.
4. Set RV901 (Tracking Volume) to its center position and confirm that a nearly maximum level is obtained.  
Then rotate the RV901 (Tracking Volume) in both directions while adjusting the height of "Guide rollers", in order to obtain the envelope waveform which is as flat as possible.  
If the tape is above or lower the helical tape position, the envelope waveforms will take the shape as shown in Fig-11 and Fig-12.
5. Adjust for maximum flatness of the envelope waveform according to the Fig-11 and Fig-12.
6. After adjustment, rotate RV901 (Tracking Volume) counterclockwise and clockwise, and check that the waveform changes symmetrically.
7. Check the tape curl. (Refer to Section 2)

	Tape is too high	
	Supply side	Take-up side
When the tracking volume is rotated counterclockwise and clockwise directions.		
		
Adjustment	Supply side "Guide roller" rotated clockwise direction (lowers "Guide roller") to flatten envelope.	Take-up side "Guide roller" rotated clockwise direction (lowers "Guide roller") to flatten envelope.

Fig-11



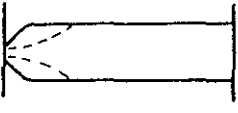
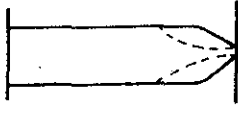
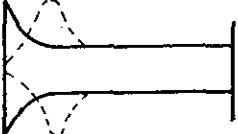
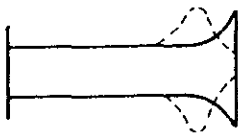

	Tape is too low	
	Supply side	Take-up side
When the tracking volume is rotated counterclockwise and clockwise directions.		
		
Adjustment	Supply side "Guide roller" rotated counterclockwise direction (raises "Guide roller") to flatten envelope.	Take-up side "Guide roller" rotated counterclockwise direction (raises "Guide roller") to flatten envelope.

Fig-12

## 6. ACE HEAD HEIGHT/ACE HEAD TILT ADJUSTMENT

### MEASURING METHOD

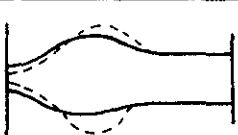
Measuring Point	Measuring Equip.	ADJ. Condition
AUDIO OUTPUT	Oscilloscope AC voltmeter	PLAY (SP) MODE Test tape TTV-P1
ADJ. Location		ADJ. Value
Height adjustment nut		Maximum level (AC voltmeter)
Azimuth adjustment screw		
Tilt adjustment screw		

### TEST EQUIPMENT CONNECTING DIAGRAMS

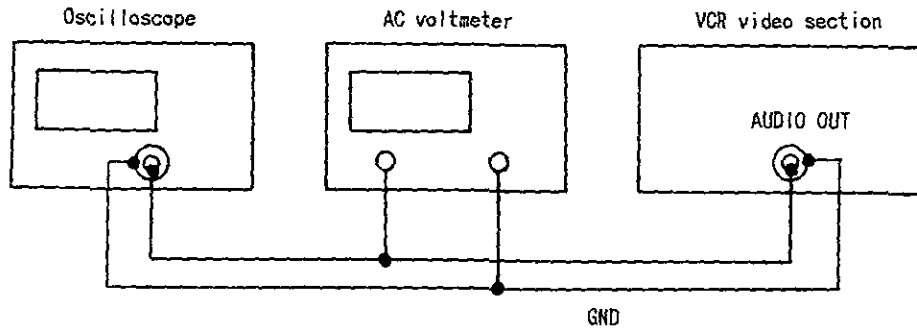

Fig-13

1. Connect equipment as shown in Fig-13.
2. Confirm that the running between the "Take-up guide roller" and the "ACE head" has no slack. If the tape has slack, take it up by turning the "Tilt adjustment screw (C)". (See Figure-15)  
Then readjust "Guide roller" height in section 2 and the "X value" in section 4.
3. After confirming on the oscilloscope that a 1kHz audio signal is being output by playing back TTV-P1 test tape, adjust the "Height adjustment nut (A)" so that the AC voltmeter's reading is brought to its maximum level. (See Figure-7)
4. Adjust the "Azimuth adjustment screw (B)" so that the AC voltmeter's reading is brought to its maximum level. (See Figure-7)

## 7. ACE HEAD AZIMUTH ADJUSTMENT

### MEASURING METHOD

Measuring Point	Measuring Equip.	ADJ. Condition
AUDIO OUTPUT	Oscilloscope AC voltmeter	PLAY (SP) MODE Test tape TTV-P2
ADJ. Location		ADJ. Value
Azimuth adjustment nut		Maximum level (AC voltmeter)

Fig-14

### TEST EQUIPMENT CONNECTING DIAGRAMS

See Figure-13.

1. After confirming on the oscilloscope that a 6kHz audio signal is being output by playing back TTV-P2 test tape, adjust the "Azimuth adjustment screw (B)" so that the AC voltmeter's reading or oscilloscope waveform is brought to its maximum level. (See Figure-15)

Note : Fix the screw (B) and (C) with lock paint after readjustment.

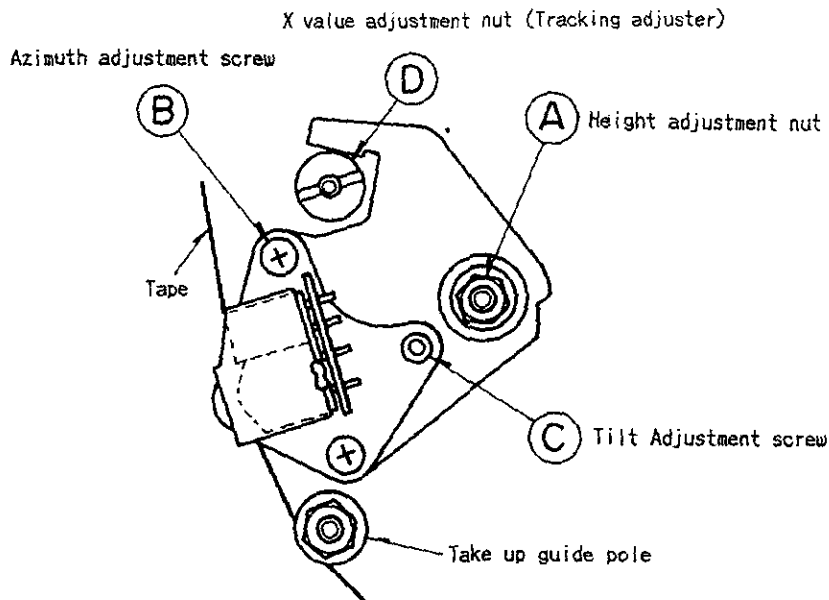
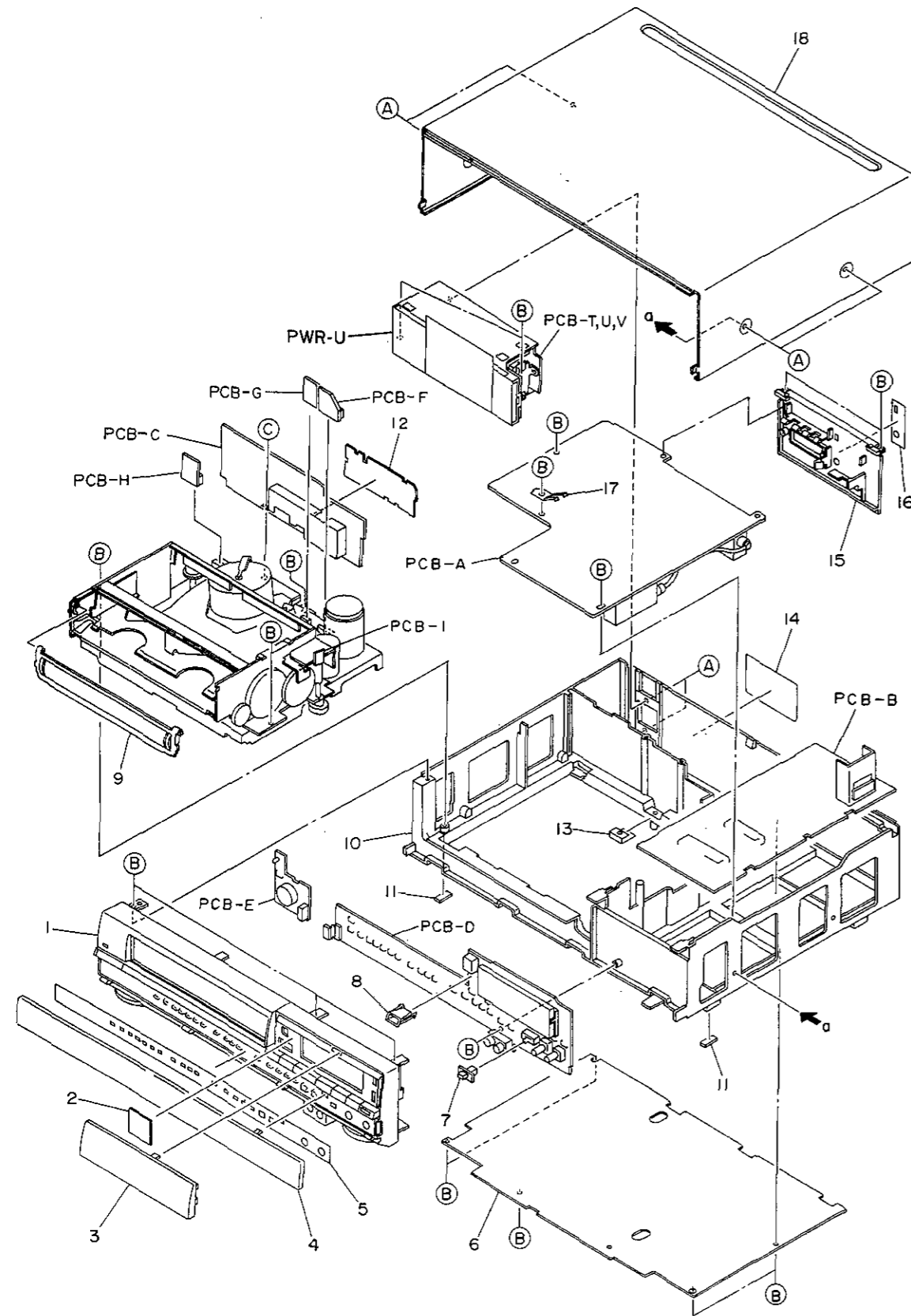

Fig-15

EXPLODED VIEW-1



EXPLODED VIEW..(1) CABINET PARTS LIST

REF. NO.	PARTS NO.	DESCRIPTION	REMARKS
I- 1	*9A02488100	CABINET FRONT ASSY	
I- 2	*9A02527800	FILTER, (T)...(MV-308 ONLY)	
I- 2	*9A02532300	FILTER, 9JU-6. (MV-307 ONLY)	
I- 3	*9A02426600	WINDOW, (T)	
I- 4	*9A02426300	DOOR, 308....(MV-308 ONLY)	
I- 4	*9A02532400	DOOR, 307....(MV-307 ONLY)	
I- 5	*9A02425600	PLATE, TIMER..(MV-308 ONLY)	
I- 5	*9A02532100	PLATE, TIMER..(MV-307 ONLY)	
I- 6	*9A02424500	BOTTOM,	
I- 7	*9A02424700	KNOB, SLIDE	
I- 8	*9A02424800	REFLECTOR,	
I- 9	*9A02426400	DOOR, CASSETTE (MV-308 ONLY)	
I- 9	*9A02532500	DOOR, CASSETTE (MV-307 ONLY)	
I-10	*9A02532000	CAB, MAIN	
I-11	*9A02424400	FELT, FOOT	
I-12	- - - -	SHIELD, RP2	
I-13	*9A02424600	CLAMP, EARTH	
I-14	*9A02425800	PLATE, SPEC... (MV-308 ONLY)	
I-14	*9A02532200	PLATE, SPEC... (MV-307 ONLY)	
I-15	*9A02426500	PANEL, JACK (G)	
I-16	*9A02426000	PLATE, JACK (G)	
I-17	*9A02426700	PLATE, EARTH	
I-18	*9A02424200	CAB, STEEL	
PCB-A	- - - -	MAIN PCB ASSY	
PCB-B	- - - -	SERVO/SYSCON PCB ASSY	
PCB-C	- - - -	PRE AMP/AUDIO PCB ASSY	
PCB-D	- - - -	TIMER PCB ASSY	
PCB-E	- - - -	POWER SW PCB ASSY	
PCB-F	- - - -	RELAY PCB ASSY-1	
PCB-G	- - - -	RELAY PCB ASSY-2	
PCB-H	- - - -	RELAY PCB ASSY-3	
PCB-I	- - - -	RELAY PCB ASSY-4	
PCB-T	- - - -	POWER PCB ASSY-1	
PCB-U	- - - -	POWER PCB ASSY-2	
PCB-V	- - - -	POWER PCB ASSY-3	
PWR-N	Δ *9A02527900	POWER UNIT, 5E	
(A)	9A02426800	BVT2+3-8W/O SLO.BLK	
(B)	9A02426900	BVIT3B+3-10	
(C)	9A02427000	BVIT3+2.6-8	

Parts marked with \*require longer delivery time

EXPLODED VIEW-2

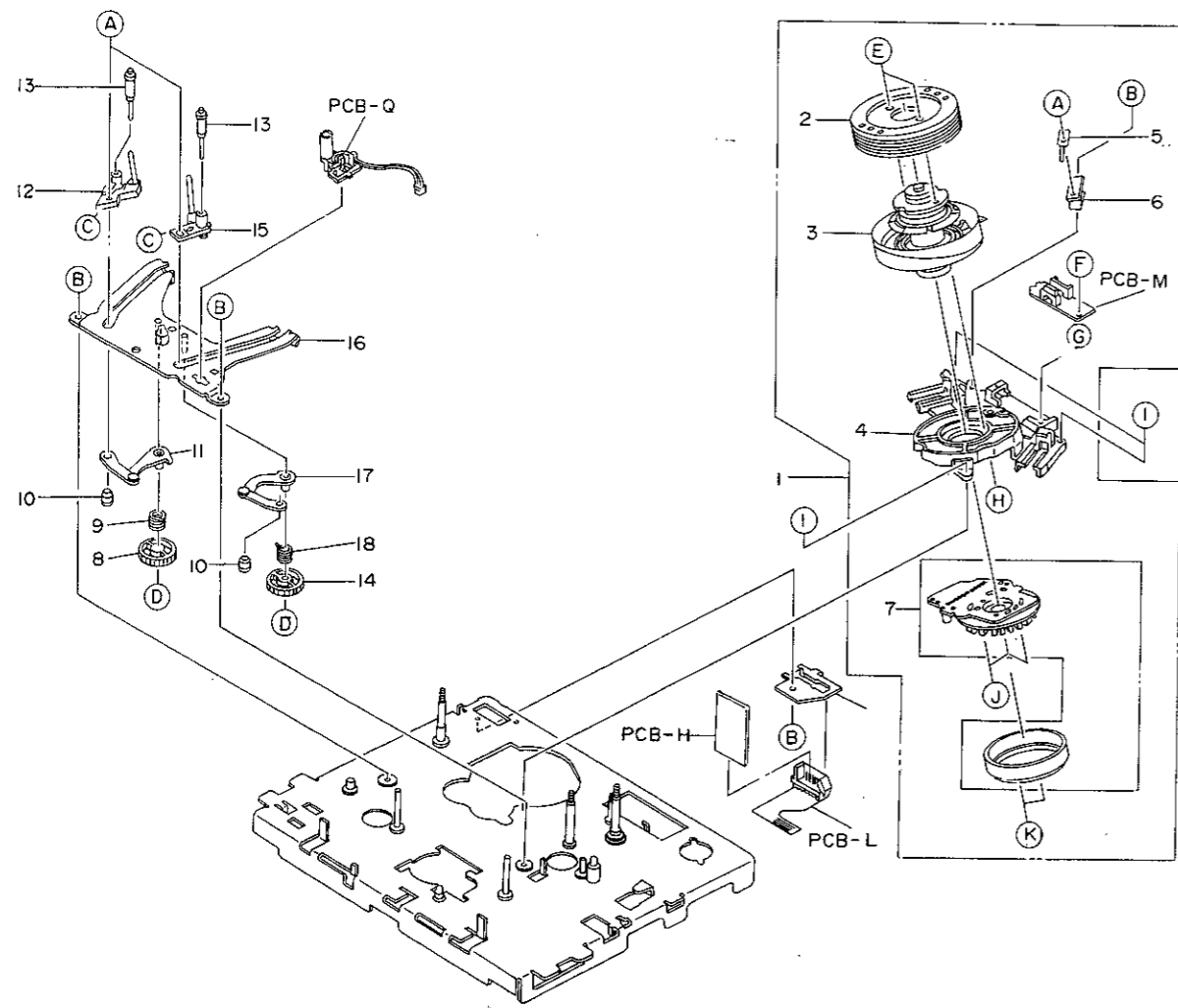

EXPLODED VIEW..(2) MECHANICAL PARTS LIST

REF. NO.	PARTS NO.	DESCRIPTION	REMARKS
	*9A02427100	MERCHA UNIT, TN5900P2SRN 104	
2- 1	*9A02492800	CYLINDER ASSY	
2- 2	*9A02492900	UPPER DRUM	
2- 3	*9A02493000	LOWER DRUM ASSY	
2- 4	*9A02493100	CYLINDER MOUNT	
2- 5	*9A02493200	DRUM EARTH	
2- 6	*9A02493300	DRUM EARTH BRACKET	
2- 7	*9A02493400	MOTOR TM82	
2- 8	*9A02493500	T LOADING GEAR L	
2- 9	*9A02493600	LOADING GEAR SPRING	
2-10	*9A02493700	LOADING BOSS	
2-11	*9A02493800	LOADING PLATE L SEMI ASSY	
2-12	*9A02493900	LOADING BLOCK L	
2-13	*9A02494000	ROLLER POST ST	
2-14	*9A02494100	T LOADING GEAR R	
2-15	*9A02494200	LOADING BLOCK R	
2-16	*9A02494300	LOADING BASE SEMI ASSY	
2-17	*9A02494400	LOADING PLATE R SEMI ASSY	
2-18	*9A02494500	LOADING GEAR SPRING	
2-19	- - - -	CONNECTOR BRACKET	

Parts marked with \*require longer delivery time

EXPLODED VIEW..(2) MECHANICAL PARTS LIST

REF. NO.	PARTS NO.	DESCRIPTION	REMARKS
PCB-H	- - - -	RELAY PCB ASSY-3	
PCB-L	- - - -	RELAY PCB ASSY-5	
PCB-M	- - - -	RELAY PCB ASSY-6	
PCB-Q	- - - -	LED PCB ASSY	
(A)	9A02491700	CUP SCREW M2.6X3	
(B)	9A02491800	C TAPPING SCREW 2.6X5	
(C)	9A02491900	SET SCR. 2.0X3(PLANE)	
(D)	9A02492000	PW CUT 2.6X6X0.5	
(E)	9A02492100	BIND TAMS SCREW 3X8	
(F)	9A02492200	W TAMS SCREW 2.6X6	
(G)	9A02492300	WASHER 2.6	
(H)	9A02492400	SCREW(FOR CAMERA)2X5	
(I)	9A02492500	C TAPPING SCREW 3X10	
(J)	9A02492600	SCREW 2.6X2.0	
(K)	9A02492700	TAMS SCREW 2.6X6	

EXPLODED VIEW..(3) MECHANICAL PARTS LIST

REF. NO.	PARTS NO.	DESCRIPTION	REMARKS
3- 1	*9A02495500	BT ACTUATE PLA. SPRING	
3- 2	*9A02495600	S SOFT BRAKE ASSY	
3- 3	*9A02495700	S SOFT BRAKE SPRING	
3- 4	*9A02495800	BAND HOLDER SPRING	
3- 5	*9A02495900	BT BAND ASSY	
3- 6	*9A02496000	BAND HOLDER COLLAR	
3- 7	*9A02496100	BT ARM SEMI ASSY	
3- 8	*9A02496200	BACK TENSION SUPPOR.	
3- 9	*9A02496300	DAMPER RUBBER	
3-10	*9A02496400	TRACKING ADJUSTER	
3-11	*9A02496500	TAPE GUIDE SPRING	
3-12	*9A02496600	TAPE GUIDE FLANGE D	
3-13	*9A02496700	TAPE GUIDE	
3-14	*9A02496800	TAPE GUIDE FLANGE C	
3-15	*9A02496900	GUIDE CAP	
3-16	*9A02497000	OPEN ANGLE ASSY	
3-17	*9A02497100	DEW SENSOR EYH-S10R	
3-18	*9A02497200	BRAKE ACTUATE BASE SPRING	
3-19	*9A02497300	BRAKE ACTUATE BASE	
3-20	*9A02497400	BRAKE PLATE	
3-21	*9A02497500	BRAKE PLATE SPRING	
3-22	*9A02497600	TRIGGER LEVER	
3-23	*9A02497700	TRIGGER HOOK	
3-24	*9A02497800	TRIGGER LEVER SPRING	
3-25	*9A02497900	REEL ASSY	
3-26	*9A02498000	RG SLIDE PLA. COLLAR	
3-27	*9A02498100	RG SLIDE PLATE	
3-28	*9A02498200	RG SLIDE SPRING	
3-29	*9A02498300	RG SLIDE BASE	
3-30	*9A02498400	METAL HOUSING ASSY	

Parts marked with \*require longer delivery time

EXPLODED VIEW..(3) MECHANICAL PARTS LIST

REF. NO.	PARTS NO.	DESCRIPTION	REMARKS
3-31	*9A02498500	RG ARM SEMI ASSY	
3-32	*9A02498600	CAPSTAN MOTOR ASSY	
(A)	9A02494600	PW CUT 2.1X4X0.5	
(B)	9A02494700	PW CUT 2.1X5X0.5	
(C)	9A02494800	C TAPPING SCREW2.6X4	
(D)	9A02494900	NUT 3.0	
(E)	9A02495000	TAMS SCREW 2.6X4	
(F)	9A02495100	PW 3.1X6X0.5	
(G)	9A02495200	TAMS SCREW 3X4	
(H)	9A02495300	C TAPPING SCREW2.6X8	
(I)	9A02495400	NYLON WAS.2.92X5X0.5	
(J)	9A02492000	PW CUT 2.6X6X0.5	

Parts marked with \*reguire longer delivery time

EXPLODED VIEW-3

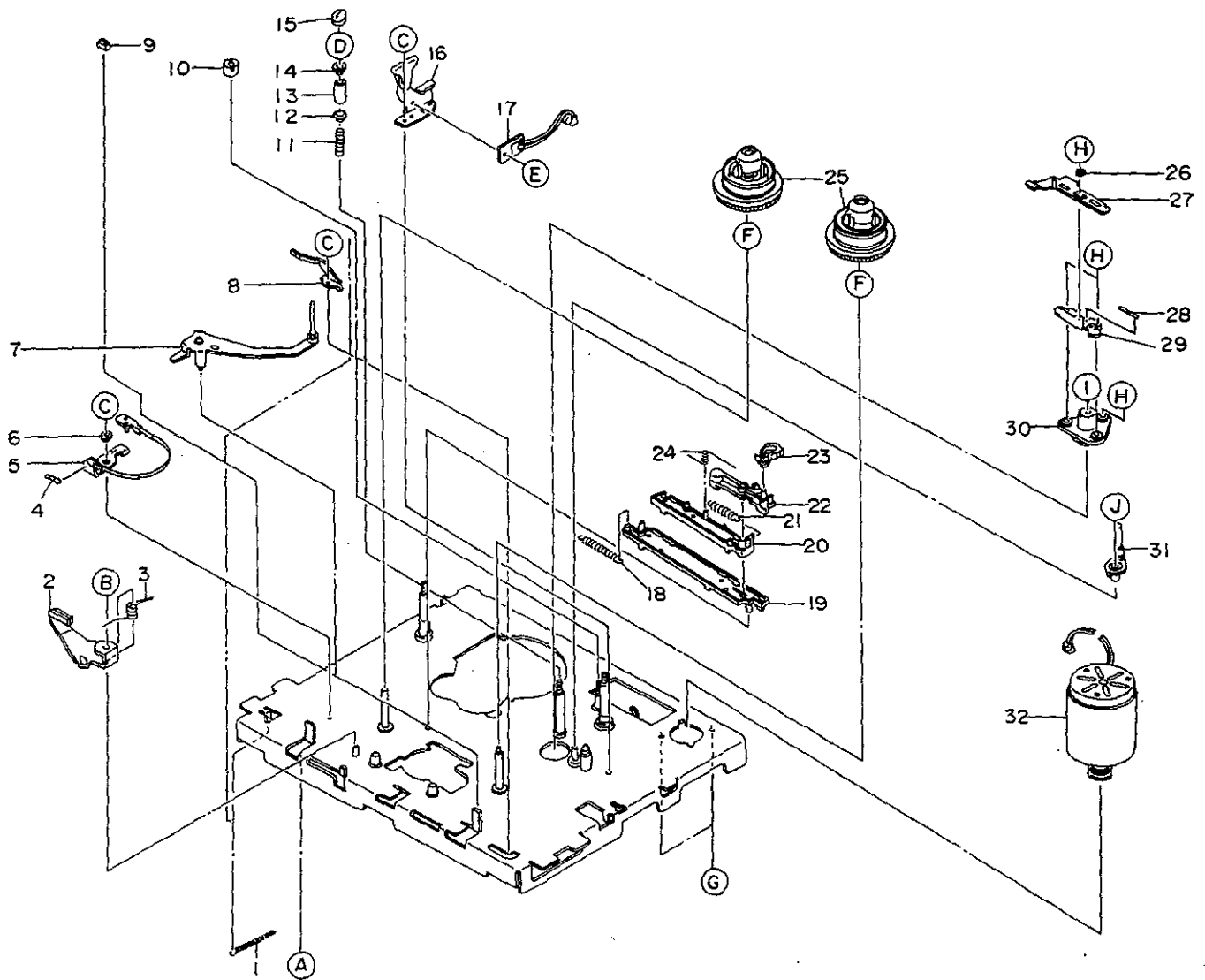

# EXPLODED VIEW-4

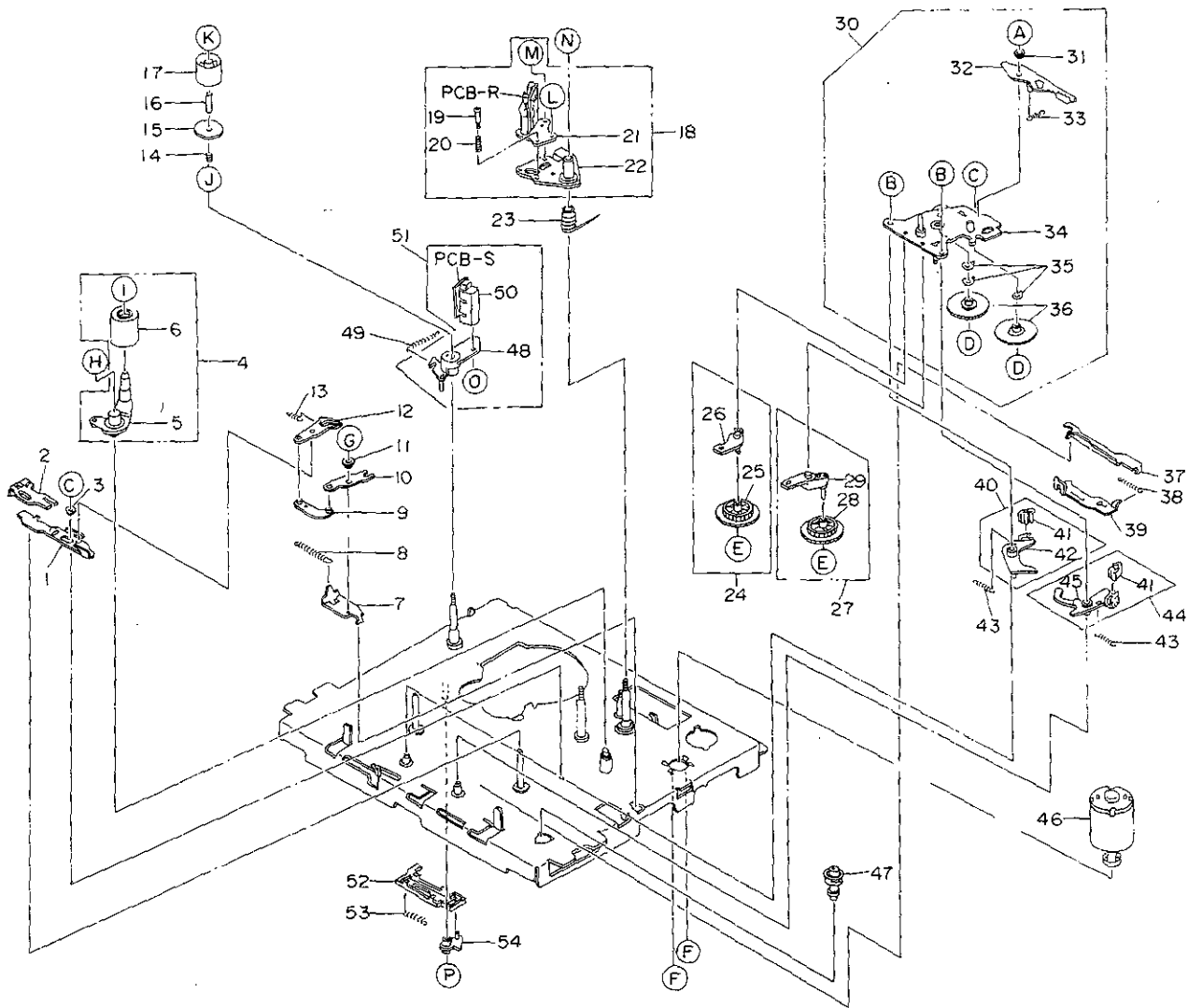

## EXPLODED VIEW..(4) MECHANICAL PARTS LIST

REF. NO.	PARTS NO.	DESCRIPTION	REMARKS
4- 1	*9A02499700	P SLIDE PLATE A	
4- 2	*9A02499800	P SLIDE PLATE B	
4- 3	*9A02499900	COLLAR	
4- 4	*9A02500000	PINCH ROLLER ARM ASY	
4- 5	*9A02500100	PINCH ROLLER ARM SEMI ASY	
4- 6	*9A02500200	PINCH ROLLER A	
4- 7	*9A02500300	P ANGLE HOLDER	
4- 8	*9A02500400	P-SPRING, ROLLER	
4- 9	*9A02500500	JOINT PLATE	
4-10	*9A02500600	P ACTUATE ANGLE	
4-11	*9A02499900	COLLAR	
4-12	*9A02500700	P ACTUATE ARM	
4-13	*9A02500800	P-SPRING,ACTUAT.ARM	
4-14	*9A02500900	TAPE GUIDE FLANGE SPRING	
4-15	*9A02501000	TAPE GUIDE FLANGE A	

Parts marked with \*require longer delivery time



## EXPLODED VIEW..(4) MECHANICAL PARTS LIST

REF. NO.	PARTS NO.	DESCRIPTION	REMARKS
4-16	*9A02501100	IMPEDANCE ROLLER SLEEVE	
4-17	*9A02501200	IMPEDANCE ROLLER	
4-18	*9A02501300	HEAD BASE ASSY	
4-19	- - - -	AZIMUTH SPRING SCREW	
4-20	- - - -	AZIMUTH SPRING	
4-21	*9A02501400	ACE HEAD HV225211	
4-22	- - - -	HEAD BASE SEMI ASSY	
4-23	- - - -	HEAD SPRING	
4-24	*9A02501500	P GEAR ASSY	
4-25	*9A02501600	PLAY GEAR	
4-26	*9A02501700	P GEAR ARM ASSY	
4-27	*9A02501800	RF GEAR ASSY	
4-28	*9A02501900	FF GEAR	
4-29	*9A02502000	RF GEAR ARM ASSY	
4-30	*9A02502100	SUB PLATE ASSY	
4-31	*9A02502200	T SOFT BRAKE ARM COLLAR	
4-32	*9A02502300	T SOFT BRAKE ASSY	
4-33	*9A02502400	T-SPRING, SOFT BRAKE ARM	
4-34	- - - -	SUB PLATE SEMI ASSY	
4-35	*9A02502500	WAVE WASHER	
4-36	*9A02502600	REEL DRIVE GEAR	
4-37	*9A02502700	BRAKE LIFTER	
4-38	*9A02502800	L BRAKE ACTUATOR SPRING	
4-39	*9A02502900	L BRAKE ACTUATOR	
4-40	*9A02503000	S BRAKE ARM ASSY	
4-41	*9A02503100	BRAKE SHOE	
4-42	*9A02503200	S BRAKE ARM	
4-43	*9A02503300	BRAKE ARM SPRING	
4-44	*9A02503400	T BRAKE ARM ASSY	
4-45	*9A02503500	T BRAKE ARM	
4-46	*9A02503600	LM ASSY	
4-47	*9A02503700	TRIGGER BEARING ASSY	
4-48	- - - -	FE PLATE	
4-49	*9A02503800	FE PLATE SPRING	
4-50	*9A02503900	FE HEAD HVFMD 0006	
4-51	*9A02504000	FE PLATE ASSY	
4-52	*9A02504100	FE SLIDE PLATE	
4-53	*9A02504200	FE ACTUATE SPRING	
4-54	*9A02504300	FE ACTUATE LEVER	
PCB-R	- - - -	ACE HEAD PCB ASSY	
PCB-S	- - - -	ERASE HEAD ASSY	
(A)	9A02498700	SL FH SCREW 2X3	
(B)	9A02498800	TAMS SCREW 2X4	
(C)	9A02491800	C TAPPI.SCREW 2.6X5	
(D)	9A02498900	E RING S1.5	
(E)	9A02499000	PW CUT 1.6X3.8X0.3	
(F)	9A02495200	TAMS SCREW 3X4	
(G)	9A02495000	TAMS SCREW 2.6X4	
(H)	9A02499100	PW CUT 5X8X0.5	
(I)	9A02499200	SCREW 2.6X4	
(J)	9A02499300	PLANE WASHER3X8X0.5	
(K)	9A02499400	NYLON NUT M3	
(L)	9A02499500	SCREW3.6(SHAPE TYPE)	
(M)	9A02499600	LONG LOCK SCREW2.6X7	
(N)	9A02499400	NYLON NUT M3	
(O)	9A02539500	SCREW FLANGE 2X3	
(P)	9A02494700	PW CUT 2.1X5X0.5	

Parts marked with \*require longer delivery time

EXPLODED VIEW-5

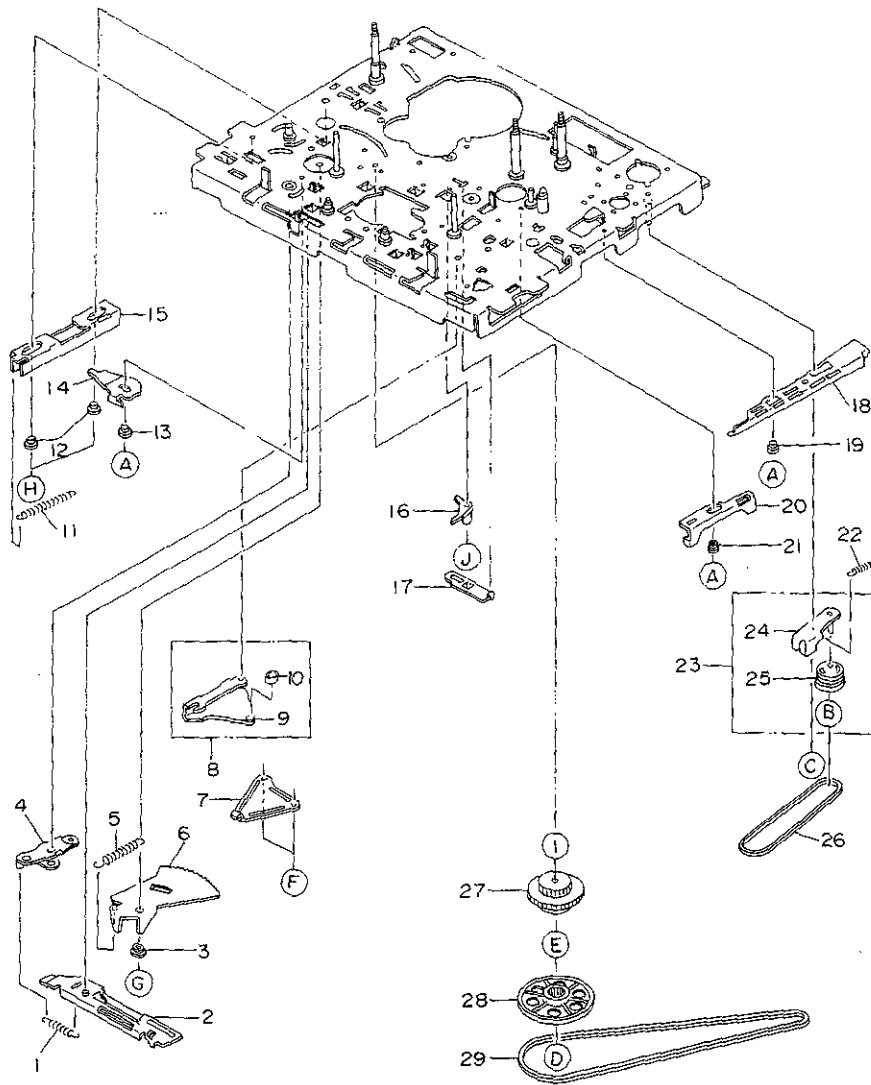

## EXPLODED VIEW..(5) MECHANICAL PARTS LIST

REF. NO.	PARTS NO.	DESCRIPTION	REMARKS
5- 1	*9A02504900	LOADING ACTUATOR SPRING	
5- 2	*9A02505000	LOADING ACTUATOR SEMI ASSY	
5- 3	*9A02505100	L GEAR PLATE COLLAR	
5- 4	*9A02505200	LOAD.ACTUA.LEVER SEMI ASSY	
5- 5	*9A02505300	L GEAR PLATE SPRING	
5- 6	*9A02505400	L GEAR PLATE	
5- 7	*9A02505500	LOAD.LEVER REINFORC.PLATE	
5- 8	*9A02505600	LOADING LEVER ASSY	
5- 9	- - - -	LOADING LEVER SEMI ASSY	
5-10	- - - -	CAM ROLLER	
5-11	*9A02505700	BACK TENSION SPRING	
5-12	*9A02505800	BT ACTUATE PLATE COLLAR	
5-13	*9A02499900	COLLAR	
5-14	*9A02505900	BT ACTUATE LEVER	
5-15	*9A02512100	BT ACTUATE PLATE	
5-16	*9A02506000	RG ACTUATE ARM	
5-17	*9A02506100	RG ACTUATE	
5-18	*9A02506200	L BRAKE PLATE	
5-19	*9A02499900	COLLAR	
5-20	*9A02506300	EJECT ACTUATOR	
5-21	*9A02499900	COLLAR	
5-22	*9A02506400	IDLER ARM SPRING	
5-23	*9A02506500	E IDLER ARM ASSY	
5-24	- - - -	E IDLER ARM SEMI ASSY	
5-25	- - - -	EJECT PULLEY	
5-26	*9A02506600	FL BELT	
5-27	*9A02506700	CLUTCH ASSY	
5-28	*9A02506800	MIDDLE PULLEY ASSY	
5-29	*9A02506900	DRIVE BELT	
(A)	9A02491800	C TAPPI.SCREW 2.6X5	
(B)	9A02499000	PW CUT 1.6X3.8X0.3	
(C)	9A02494700	PW CUT 2.1X5X0.5	
(D)	9A02492000	PW CUT 2.6X6X0.5	
(E)	9A02504400	NYLON WA.2.98X6X0.3	
(F)	9A02504500	TAMS SCREW 2X5	
(G)	9A02504600	C TAPPING SCREW 3X6	
(H)	9A02504700	S TAPP.SCREW2.6X3.5	
(I)	9A02504800	NYLON WAS.3.1X6X0.3	
(J)	9A02494700	PW CUT 2.1X5X0.5	

Parts marked with \*require longer delivery time

EXPLODED VIEW-6

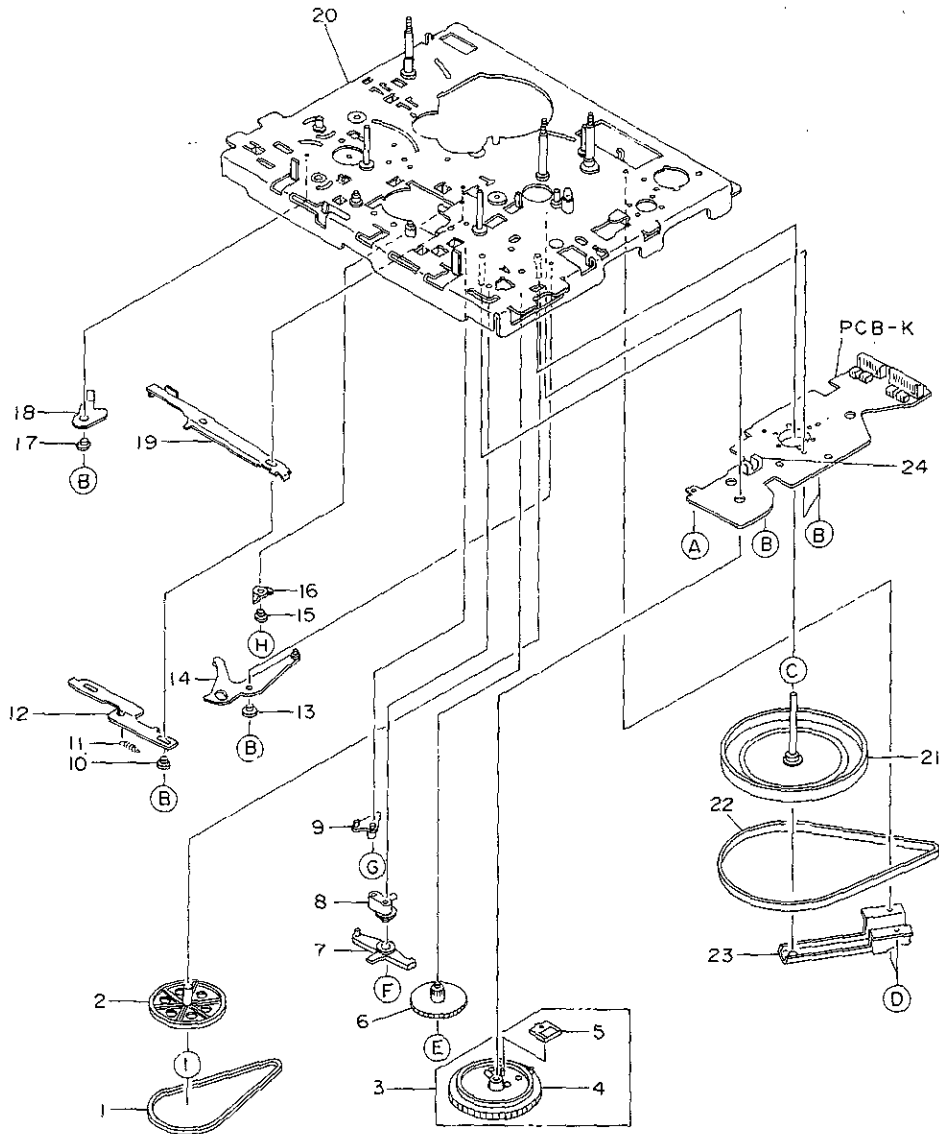

## EXPLODED VIEW..(6) MECHANICAL PARTS LIST

REF. NO.	PARTS NO.	DESCRIPTION	REMARKS
6- 1	*9A02507400	LOADING BELT	
6- 2	*9A02507500	LOADING PULLEY	
6- 3	*9A02507600	LOADING CAM ASSY	
6- 4	- - - -	LOADING CAM	
6- 5	- - - -	S BRUSH	
6- 6	*9A02507700	LOADING GEAR	
6- 7	*9A02507800	EJECT ARM	
6- 8	*9A02507900	BRAKE ACTUATE ARM	
6- 9	*9A02508000	SEARCH ARM B	
6-10	*9A02508100	P SLIDER COLLAR	
6-11	*9A02508200	P-SPRING, SLIDER	
6-12	*9A02508300	P SLIDER	
6-13	*9A02508400	P CAM LEVER COLLAR	
6-14	*9A02508500	P CAM LEVE SEMI ASSY	
6-15	*9A02508600	P CRANK COLLAR	
6-16	*9A02508700	P CRANK	
6-17	*9A02499900	COLLAR	
6-18	*9A02508800	BT RETURN LEVER	
6-19	*9A02508900	BT CHANGE PLATE	
6-20	- - - -	CHASSIS SEMI ASSY	
6-21	*9A02509000	FLYWHEEL CAPSTAN	
6-22	*9A02509100	MAIN BELT	
6-23	*9A02509200	FL ANGLE ASSY	
6-24	*9A02509300	REEL SENSOR	
PCB-K	- - - -	BASE PCB ASSY	
(A)	9A02507000	S TAPPING SCREW 2.6X5	
(B)	9A02491800	C TAPP. SCREW 2.6X5	
(C)	9A02495100	PW 3.1X6X0.5	
(D)	9A02507100	C TAPPING SCREW 3X5	
(E)	9A02494700	PW CUT 2.1X5X0.5	
(F)	9A02507200	PW CUT 2.6X8X0.5	
(G)	9A02492000	PW CUT 2.6X6X0.5	
(H)	9A02507300	C TAPP.FH SCREW 2.6X4	
(I)	9A02499000	PW CUT 1.6X3.8X0.3	

Parts marked with \*require longer delivery time

EXPLODED VIEW-7

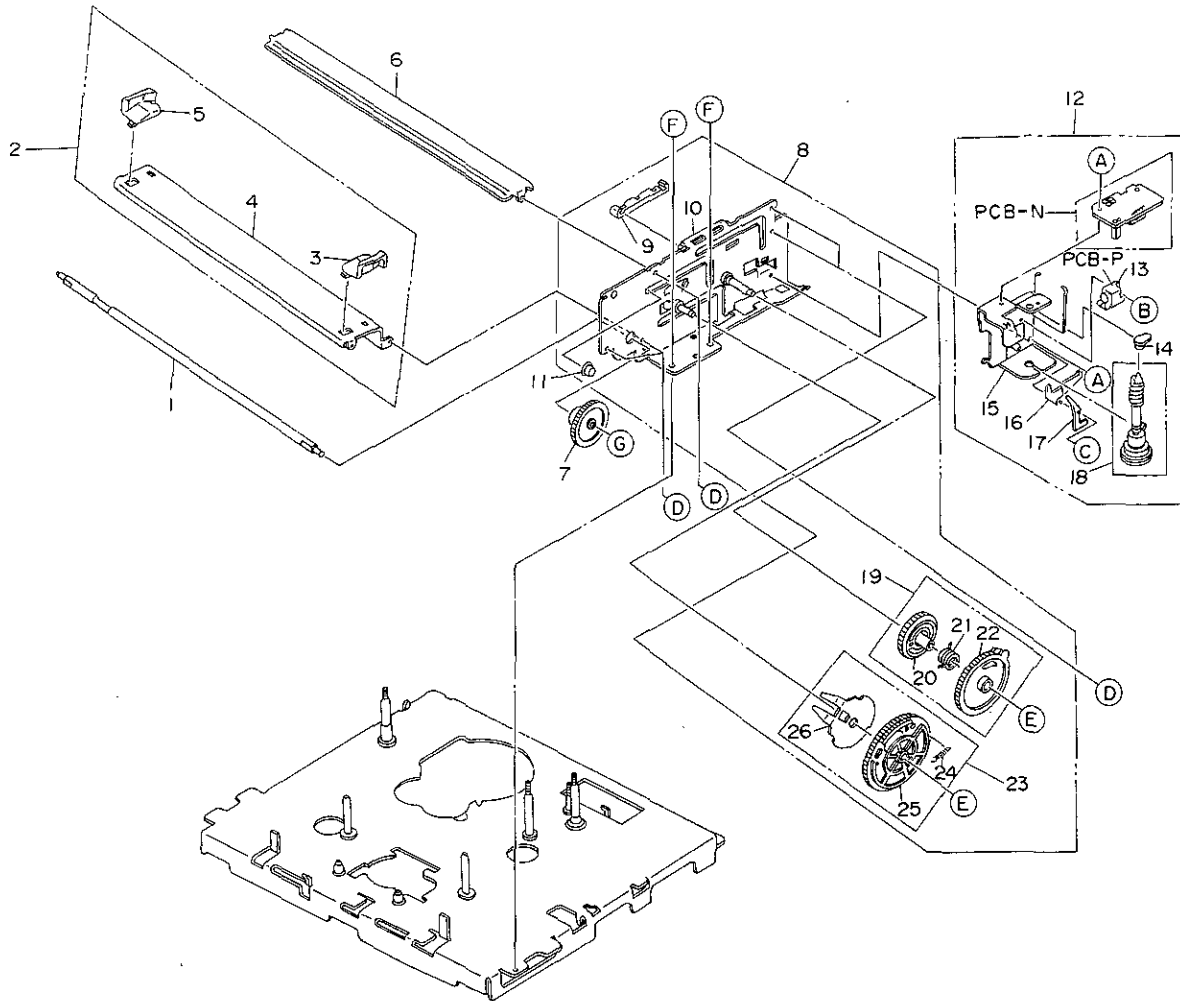

EXPLODED VIEW..(7) MECHANICAL PARTS LIST

REF. NO.	PARTS NO.	DESCRIPTION	REMARKS
7- 1	*9A02509500	SYNCHRONIZE SHAFT	
7- 2	- - - -00	FRONT ANGLE ASSY	
7- 3	*9A02509600	TAPE GUIDE R	
7- 4	*9A02509700	FRONT ANGLE	
7- 5	*9A02509800	TAPE GUIDE L	
7- 6	*9A02509900	UPPER PLATE	
7- 7	*9A02510000	SYNCHRONIZE GEAR A	
7- 8	*9A02510100	FRAME R ASSY	
7- 9	- - - -	OPEN LEVER GUIDE	
7-10	- - - -	FRAME R SEMI ASSY	
7-11	- - - -	GUIDE SLEEVE	
7-12	*9A02510200	C LOAD BRACKET ASSY	
7-13	- - - -	SENSOR PCB SEMI ASSY	
7-14	- - - -	F WORMBEARING A	
7-15	- - - -	C COAD BRACKET SEMI ASSY	
7-16	- - - -	IN SW LEVER	
7-17	- - - -	S SW LEVER	
7-18	*9A02510300	F LOADIN.CLUTCH ASY	
7-19	*9A02510400	WORMWHEEL ASSY	
7-20	- - - -	FRICTION GEAR	
7-21	- - - -	FRICTION SPRING	
7-22	- - - -	WOAM WHEEL	
7-23	*9A02510500	LIFT GEAR R ASSY	
7-24	- - - -	LP SPRING	
7-25	- - - -	LIFT GEAR R	
7-26	- - - -	LIFT ARM	
PCB-N	- - - -	SW PCB ASSY	
PCB-P	- - - -	END SENSOR PCB ASSY	
(A)	9A02495000	TAMS SCREW 2.6X4	
(B)	9A02504500	TAMS SCREW 2X5	
(C)	9A02499000	PW CUT 1.6X3.8X0.3	
(D)	9A02495000	TAMS SCREW 2.6X4	
(E)	9A02509400	E RING S2.5	
(F)	9A02491800	C TAPPI.SCREW 2.6X5	
(G)	9A02509400	E RING S2.5	

Parts marked with \*require longer delivery time

# EXPLODED VIEW-8

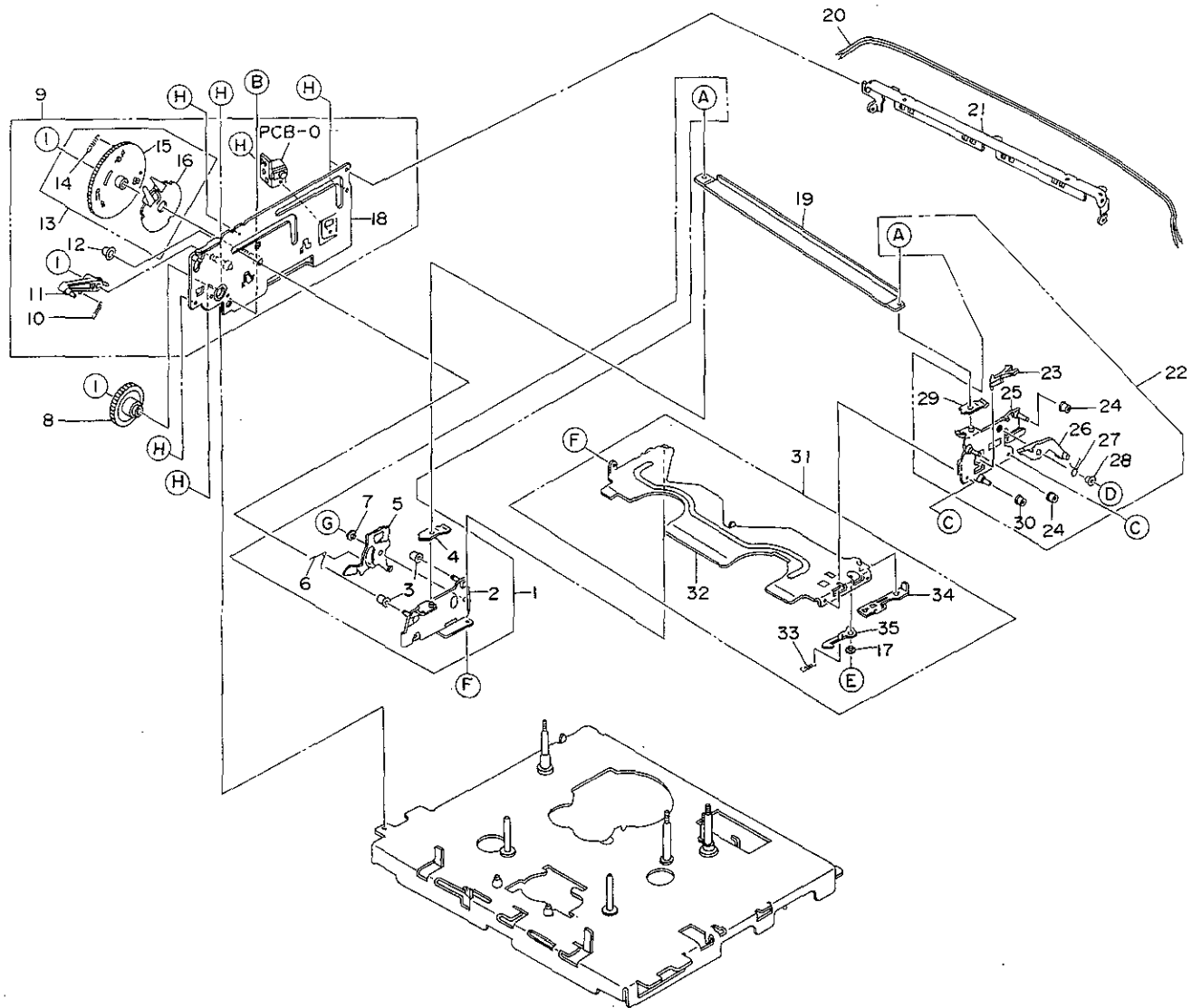



## EXPLODED VIEW..(8) MECHANICAL PARTS LIST

REF. NO.	PARTS NO.	DESCRIPTION	REMARKS
8- 1	*9A02511200	SIDE PLATE L ASSY	
8- 2	- - - -	SIDE PLATE SEMI ASSY	
8- 3	- - - -	GUIDE ROLLER	
8- 4	- - - -	CASSETTE PUSH PLATE	
8- 5	- - - -	C LOCK PLATE L	
8- 6	- - - -	LOCK PLATE SPRING L	
8- 7	- - - -	LOCK PLATE COLLAR	
8- 8	*9A02510000	SYNCHRONIZE GEAR A	
8- 9	*9A02511300	FRAME L ASSY	
8-10	- - - -	LIFT LEVER SPRING	
8-11	*9A02511400	LIFT LEVER	
8-12	- - - -	GUIDE SLEEVE	
8-13	*9A02511500	LIFT GEAR L ASSY	
8-14	- - - -	LP SPRING	
8-15	- - - -	LIFT GEAR L	
8-16	- - - -	LIFT ARM	
8-17	- - - -	COLLAR	
8-18	- - - -	FRAME L SEMI ASSY	
8-19	*9A02511600	TOP STAY	
8-20	- - - -	ENG SENSOR WIRE	
8-21	*9A02511700	REAR ANGLE	
8-22	*9A02511800	SIDE PLATE R ASSY	
8-23	- - - -	LOCK RELEASE LEVER	
8-24	- - - -	GUIDE ROLLER	
8-25	- - - -	SIDE PLATE R SEMI ASSY	
8-26	*9A02511900	OPEN LEVER	
8-27	- - - -	OPEN LEVER SPRING	
8-28	- - - -	OPEN LEVER COLLAR	
8-29	- - - -	CASSETTE PUSH PLATE	
8-30	- - - -	GUIDE ROLLER	
8-31	*9A02512000	CASSETTE HOLDER ASSY	
8-32	- - - -	CASSETTE HOLDER	
8-33	- - - -	LOCK SPRING	
8-34	- - - -	SLIDE PLATE	
8-35	- - - -	C LOCK PLATE A	
PCB-0	- - - -	START SENSOR PCB ASSY	
(A)	9A02510600	SCREW 2.3X2	
(B)	9A02491800	C TAPP1.SCREW 2.6X5	
(C)	9A02510700	SCREW 2.6X3	
(D)	9A02510800	SL SCREW 2X4	
(E)	9A02510900	SL SCREW 2.6X3	
(F)	9A02511000	SCREW 2.3X2.5	
(G)	9A02511100	SL SCREW 2X2.5	
(H)	9A02495000	TAMS SCREW 2.6X4	
(I)	9A02509400	E RING S2.5	

Parts marked with \*require longer delivery time

INCLUDED ACCESSORIES PARTS LIST

REF. NO.	PARTS NO.	DESCRIPTION	REMARKS
	*9A02373200	OWNER'S MANUAL, (MV-307/308)	
	9A02460200	CORD, RF PAL	
	9A02460300	AC CORD ASSY,	
	-----	SUM-3 (MAXELL 2P)	
	*9A02460600	REMOCON UNIT, RC-398 (MV-308 ONLY)	
	*9A02531940	REMOCON UNIT, RC-397 (MV-307 ONLY)	

Parts marked with \*require longer delivery time



### DRUM SERVO SYSTEM TIMING CHART

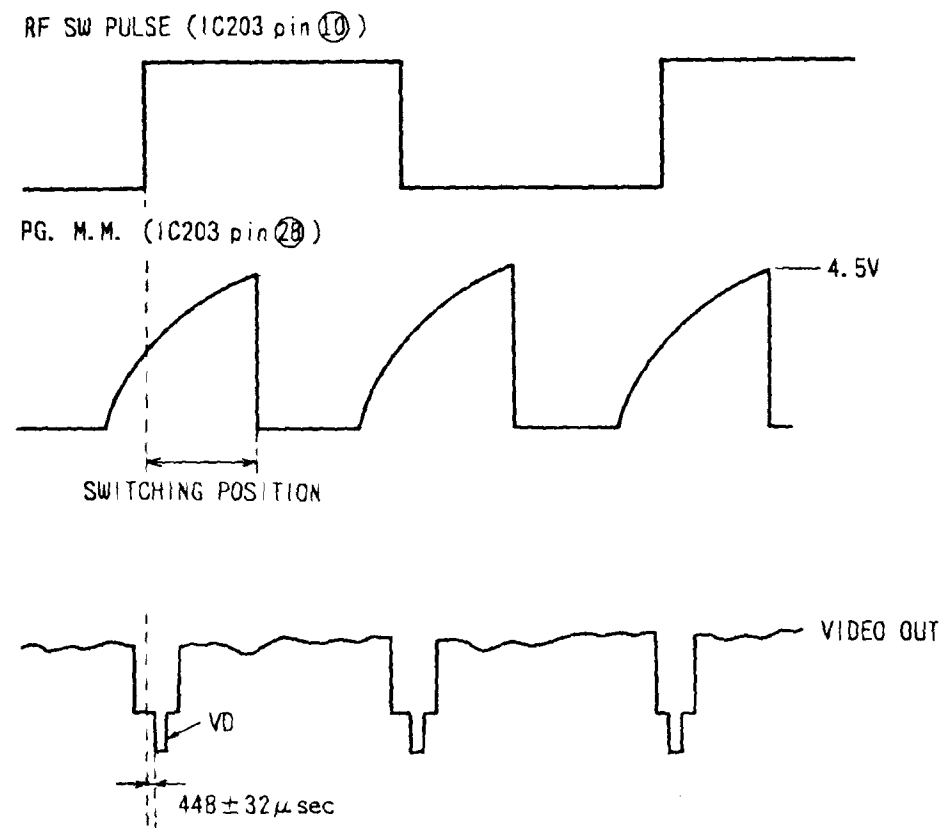
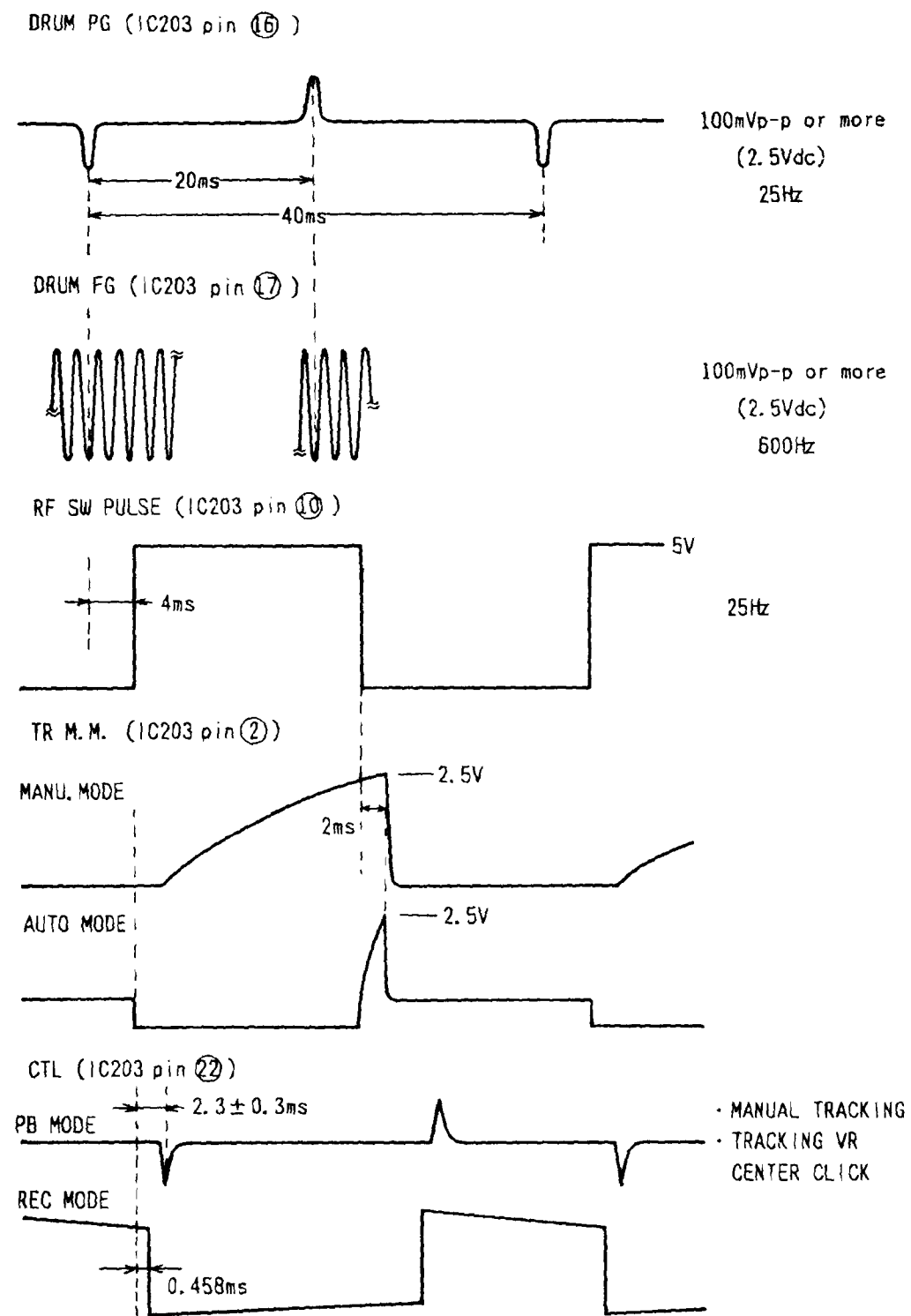

### NOISE CANCELLER TIMING CHART

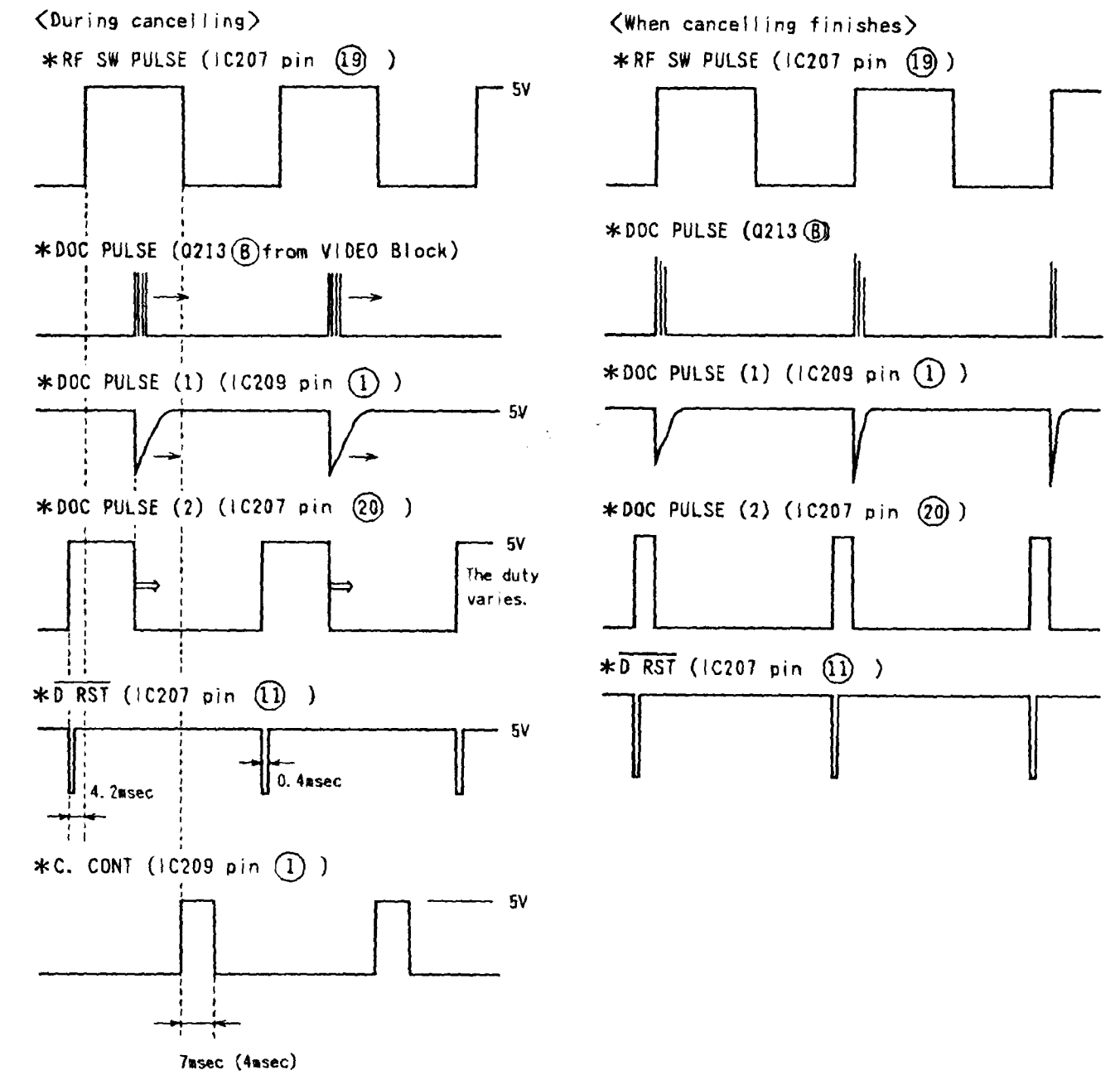

※This is a wave form when a noise bar is moved by slightly turning the capstan motor gradually using the C. CONT pulse.